

Product range

Middle East

Edition 2018

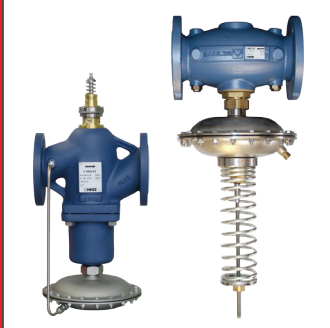

HERZ Middle East FZE
SAIF Zone, Sharjah, UAE, P.O. Box 121310
Tel.: +971 (0)6 55 28 108
Fax: +971 (0)6 55 28 109
E-Mail: office@herz.ae
www.herz.ae

CERTIFICATIONS

Bescheinigung Certificate

Über die Zuerkennung eines Bescheinigungszertifikats für

Sicherheitsventile

Aufgrund einer Baueingriff-Probefahrt des TÜV Süd vom 24.10.2011 wird dem Antragsteller, der Firma **HERZ d.d.**, Gmatska cesta 3, SI-1275 Šmartno pri Litiji, Slowenien, die Zuerkennung eines Bescheinigungszertifikats für **TÜV + SV + 11-1132 + 13.8 + H + KW + p** für **direkt wirkendes Sicherheitsventile, federbelastet** Typ **type** **VW11, VW12, VW13** (Option VWS2/AM mit gelbem Gewinde) erteilt. Die Zuerkennung erfolgt in Anwendung der VdTUV-Merkblätter (Sicherheitsventile) 100*, Ausgabe 08/2010; AD 2000-Merkblatt A2; Abschnitte 1, 2, 3, 4, 8, 9, 10 und 11; Ausgabe 03/2010; Eisenregeln: TRD 21, DIN 4751 Teile 2, 3 und 4. Sie ist bis zum 26.11.2016 befristet und kann widerrufen werden. Die Bescheinigung von ... wird hierdurch ersetzt.

Berlin, 19. November 2011

Verband der TÜV e.V. / Hohenstraße 136 - 30173 Berlin - Deutschland
Südteil-Nr. 30 30000-000 / Nordteil-Nr. 30 30000-001 / Internet: www.tuev.de

DIN-DVGW-Baumusterprüfzertifikat
DIN-DVGW type examination certificate

NG-4312C0045

Anwendungsbereich / **Field of application**: Produkte der Gasversorgung / products of gas supply

Zertifizierer / **Issuer of certificate**: Herz d.d. / Gmatska cesta 3, SI-1275 Šmartno pri Litiji

Hersteller / **Manufacturer**: Herz d.d. / Gmatska cesta 3, SI-1275 Šmartno pri Litiji

Produktart / **Product category**: Gasarmaturen: Absperrarmatur <= MOP 5 (4312)

Produktbeschreibung / **Product description**: Kupfereinheit in Durchgangsform oder Eckform, variablen mit Thermisch Auslösender Absperrmechanik (TAE)

Modell / **Model**: KROCT; K910T

Prüfberichte / **Test reports**: Baumusterprüfung: B1306/1627 vom 30.01.2013 (DB)

Prüfgrundlagen / **Test basis**: DIN EN 331 (01.08.2011)

Ablaufdatum / AZ / **date of expiry**: 30.01.2019 / 12-0005-01E

Daks

DIN-DVGW-Baumusterprüfzertifikat
DIN-DVGW type examination certificate

NG-4312B0382

Anwendungsbereich / **Field of application**: Produkte der Gasversorgung / products of gas supply

Zertifizierer / **Issuer of certificate**: Herz d.d. / Gmatska cesta 3, SI-1275 Šmartno pri Litiji

Hersteller / **Manufacturer**: Herz d.d. / Gmatska cesta 3, SI-1275 Šmartno pri Litiji

Produktart / **Product category**: Gasarmaturen: Absperrarmatur <= MOP 5 (4312)

Produktbeschreibung / **Product description**: Kupfereinheit in Durchgangsform

Modell / **Model**: KROCM/KROCM/KROCM/M-DN...

Prüfberichte / **Test reports**: Baumusterprüfung: B1306/1627 vom 13.06.2013 (DB)

Prüfgrundlagen / **Test basis**: DIN EN 331 (01.08.2011)

Ablaufdatum / AZ / **date of expiry**: 13.06.2017 / 13-0174-DNV

Daks

IQNet

THE INTERNATIONAL CERTIFICATION NETWORK

CERTIFICATE

HERZ, d.d.
Šmartno pri Litiji, Slovenija

Development, production and sales of ball valves for non aggressive mediums, sanitary mixers and heating systems

has implemented and maintains a **Management System** which meets the requirements of the standard **ISO 9001:2008**

Certification date: 1997-02-11
Issue: 05 / 2013-05-08 Validity date: 2016-02-28
Registration Number: SI - Q-066

Michael Drechsel
President of IQNet Managing Director of SIQ

SIQ

Certifikat / Certificate

za sistem izvedanja

HERZ, d.d.
Šmartno pri Litiji

Razvoj, proizvodnja in prodaja krogljnih ventilov za neagresivne medije, sanitarni armatur in sistemov za ogrevanje

has implemented and maintains a **Management System** which meets the requirements of the standard **ISO 9001:2008**

Certifikat / Certificate registration number: **Q-066 / 1997-02-11**
Izdaja: 05 / 2013-05-08 Veljavnost: 2016-02-28

SIQ, Tiskarska cesta 2, 1000 Ljubljana, Slovenija

Svjedočba br.
S - 43488/22 rev. 1

REGULATOR TLAKA VODE

HERZ d.d., Slovenija

RT-483, RT-483, RT-484, RT-484, RT-492, RT-493, RT-494, RT-495, RT-496, RT-497

HERZ d.d. - Gmatska cesta 3, SI-1275 Šmartno pri Litiji SLOVENIJA

1) Datum izpisa: 1997-02-11
2) Odlomci za: DIN 15.25.23.24.30; TLAKA PN 10 bara
3) Dimenzije: 1/2" - 2"

Zaključek (Conclusion)

ZADOVOLJIVA

17.07.2015

U.S. GREEN BUILDING COUNCIL MEMBER

HERZ MIDDLE EAST FZE

ORGANIZATIONAL

The U.S. Green Building Council is the nation's foremost coalition of leaders working to transform the way buildings and communities are designed, built, and operated, creating an environmentally and socially responsible, healthy, and prosperous environment that improves the quality of life.

Michael Drechsel
President, CEO & Founding Chair

WRAS

APPROVED PRODUCT

CERTIFICATION MARK

TÜV

MANAGEMENT SERVICE

ISO 9001

SIGNS AND SYMBOLS

SIGN	DIMENSION	UNIT
A	Length of the handle	[mm]
B	Length of the handle	[mm]
Cu	Diameter of the copper pipe	[mm]
d	Diameter of the copper pipe	[mm]
D	Length	[mm]
DN	Nominal dimension	[mm]
G	Thread dimension	[in]
G1	Thread dimension	[in]
G2	Thread dimension	[in]
H	Height	[mm]
h	Height	[mm]
H1	Length	[mm]
H2	Length	[mm]
hmax	Maximum length	[mm]
hmin	Minimum length	[mm]
L	Length	[mm]
L1	Length	[mm]
MOP	Maximum working pressure	[bar]
P	Power	[kW]
Piz	Pressure	[bar]
PN	Pressure	[bar]
Rp	Thread dimension	[in]
Rp - R	Thread dimension	[in]
Sw	Dimension of the wrench	[mm]
Sw1	Dimension of the wrench	[mm]
Sw2	Dimension of the wrench	[mm]
T	Temperature	[°C]
	Weight	[kg]

TABLE OF CONTENTS:

1. HVAC

- room thermostats
- control/thermostatic valves
- 2/3/4-port valves
- valve drives, actuating drives
- PIBCVs, combi valves
- fixed/variable orifice double regulating valves
- differential pressure controller
- butterfly valves, gate valves, shut-off valves
- check valves, strainers
- ball valves
- Connect-4
- pipes & connections

2. WATER

- pressure reducers
- drain valves
- backflow preventers
- distributors
- balancing valves, regulating valves
- mixing valves

3. GAS

- ball valves
- strainers
- accessories

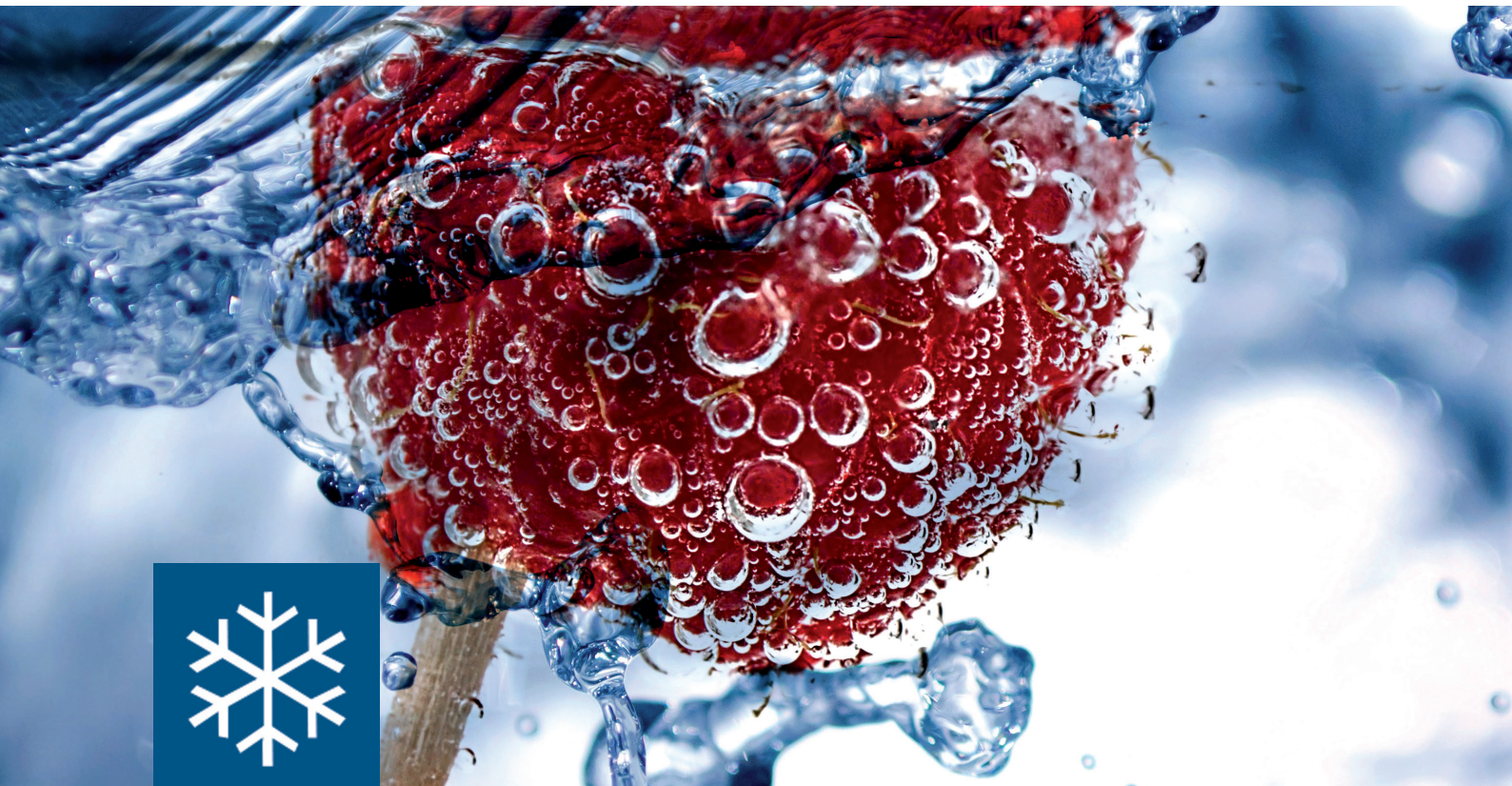

01/HVAC

Premium functionality

Room Thermostat

H 7708



Room Economic thermostat with digital display
 Supply voltage: 230V/50 Hz
 Temperature Range: 5°C - 35°C
 Easy Temperature adjustments with up - down arrows
 Auto fan with adjustable 3 fan speed.
 RS 485 Communication
 Dimension: 86 x 86 x 15 mm

Order number	Supply voltage
H 7708	230 V

H 7709



Room thermostat with large digital display
 Supply voltage: 230V/50 Hz
 Temperature Range: 5°C - 35°C
 Easy Temperature adjustments with up - down arrows
 Auto fan with adjustable 3 fan speed.
 7 days programmable.
 Dimension: 86 x 86 x 15 mm

Order number	Supply voltage
H 7709	230 V

H 7711



Room Modulating thermostat with digital display
 Supply voltage: 24V/50Hz
 Temperature Range: 5°C - 35°C
 Easy Temperature adjustments with up - down arrows
 Auto fan with adjustable 3 fan speed.
 0-10v/4-20mA modulating valve control
 Dimension; 86 x 86 x 23 mm

Order number	Supply voltage
H 7711	24 V

H 7712

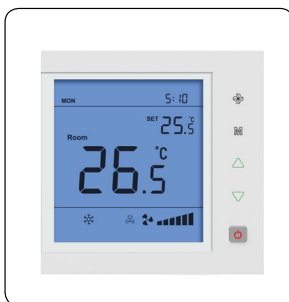

Herz Room thermostat with large digital display
 Supply voltage : 230V/50 Hz
 Temperature Range : 5°C - 35°C
 Easy Temperature adjustments with up - down arrows
 Auto fan with adjustable 3 fan speed.
 7 days programmable with timer function
 Dimension : 90 x 90 x 15 mm

Order number	Supply voltage
H 7712	230 V



Room Thermostat

H 7713



Herz Economic Digital Room thermostat
 Supply voltage : 230V/50 Hz
 Temperature Range : 5°C - 35°C
 Easy Temperature adjustments
 Auto fan with adjustable 3 fan speed.
 Dimension 86 x 86 x 13 mm

Order number	Supply voltage
H 7713	230 V

H 7714



Herz Touch Screen Thermostat
 Supply voltage : 230V/50 Hz
 Temperature Range : 5°C - 35°C
 Easy Temperature adjustments with: large LCD Display
 Auto fan with adjustable 3 fan speed.
 Dimension 86 x 86 x 14 mm

Order number	Supply voltage
H 7714	230 V

H 7720



Fan coil thermostat
 Electrical Rating: 220V, 50/60Hz
 Fan 3-speed, on/off valve
 Standard, Modbus, WIFI model optional
 Embedded mounted

Order number	Supply voltage
H 7720	220 V

H 7721



Electrical Rating: 100 -240VAC 50/60Hz
 Fan Relay Amps inductive: 3(2)A
 Heat/Cool Relay Amps inductive: 3(2)A
 Room Temperature Setting Range: 5°C to 35°C
 Dimensions: 88mm×88mm×44mm
 Flush mount
 Touch key

Order number	Supply voltage
H 7721	240 V

FODRV Control Valve

7217 V

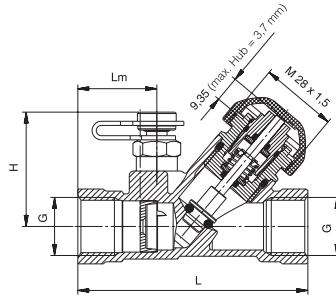
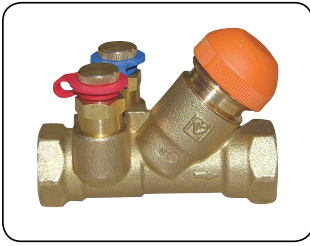

Technical data:

Max. operating temperature 130 °C
 Max. operating pressure 20 bar
 Max. differential pressure on the seat 10 bar

Material: DZR

Order number	STRÖMAX	DN	L	Lm	Rp	H	SW	Kv	Kvs
1 7217 51	TS-V LF	15	83	28.5	1/2	41	27	0.07 - 0.45	0.48
1 7217 50	TS-V MF	15	83	28.5	1/2	41	27	0.30 - 0.90	0.97
1 7217 59	TS-V	15	83	28.5	1/2	41	27	0.45 - 1.70	1.95
1 7217 52	TS-V	20	91	31	3/4	41	32	0.40 - 3.40	3.95

FODRV Control Valve

7217 GV

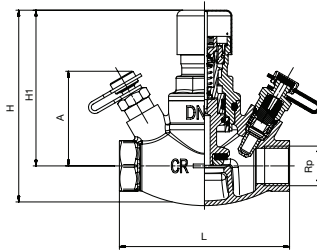

Technical data:

Max. operating pressure: 16 bar
 Max. diff. pressure on the body: 4 bar
 Max. diff. pressure on the seat: 4 bar
 Min. operating temp.: 2 °C (pure water)

Materials:

Body: DZR (CC752S)
 Bonnet: DZR (CW602)
 Sealings and O-rings EPDM

Order number	DN	Rp	L	H	H1	H + actuator	A	Kvs	M
1 7217 71	15	1/2	90	101	82	162	50	5	M 28 x 1.5
1 7217 72	20	3/4	97	101	82	162	50	5.6	M 28 x 1.5
1 7217 73	25	1	110	114	88	168	50	7.78	M 28 x 1.5

Control Valve with reverse function

7760 RD



Order number	DN	Dim.	Kvs
1 7760 51	15	G 3/4	2.81
1 7760 52	20	G 1	3.21

Technical data:

max. operating temperature: 120°C
 min. operating temperature: -20°C
 max. operating pressure: 16 bar

Materials:

Body: Brass nickel plated
 Spindle: Stainless steel
 Sealings: EPDM
 Connections: Outside threads with cone to connect with compression units
 Actuating Thread M28x1,5

CALIS-TS-RD Three-Port Valve for thermostatic operation

7761 RD



Order number	DN	R	Kvs
1 7761 38	15	3/4	3.00
1 7761 39	20	1	3.00
1 7761 40	25	1 1/4	6.44
1 7761 41	32	1 1/2	6.27

Technical data:

Max. operating temperature: 120 °C
 Min. operating temperature: 2 °C
 Max. operating pressure: DN 15, 20 10 bar
 Max. operating pressure: DN 25, 32 16 bar
 Max. pressure drop for thermostatic operation: 0.2 bar

Materials:

Valve body: brass (CC754S-GM)
 Spindle: stainless steel
 Seals: EPDM
 Upper part: cover blue plastic cap
 Thermostat threaded connection: M 28 x 1.5.



Thermostatic Valve

7760

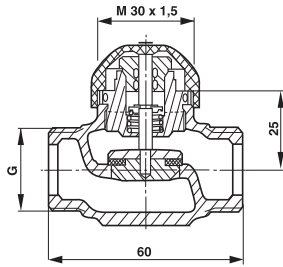

Order number	DN	G	Kvs	Stroke [mm]
1 7760 21	10	1/2	0.16	4
1 7760 01	10	1/2	0.4	4
1 7760 02	10	1/2	0.6	4
1 7760 03	10	1/2	1.0	4
1 7760 04	10	1/2	1.6	4
1 7760 05	15	3/4	2.5	4
1 7760 07	15	3/4	4.0	4
1 7760 08	20	1	5.0	

Technical data:

Max. operating temperature: 120°C
 Min. operating temperature: -20°C
 Max. operating pressure: 16 bar

Material: DZR

Thermostatic Three-Port Valves

7762

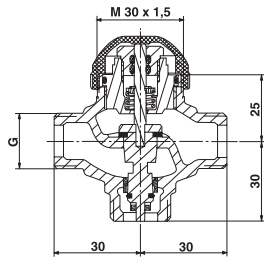

7763

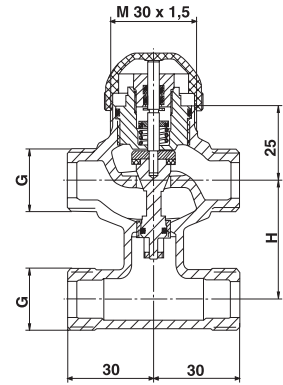

Order number	Order number	DN	G	Kvs-value straight flow	Kvs-value bypass flow	Stroke [mm]	H
1 7762 50	1 7763 50	10	1/2	0.4	0.3	3.7	40
1 7762 60	1 7763 60	10	1/2	0.6	0.5	3.7	40
1 7762 70	1 7763 70	10	1/2	1.0	0.8	3.7	40
1 7762 80	1 7763 80	10	1/2	1.6	1.2	3.7	40
1 7762 51	1 7763 51	15	3/4	2.5	1.9	3.7	40
1 7762 61	1 7763 61	15	3/4	4.0	3.0	3.7	40
1 7762 62	1 7763 62	20	1	5.0	3.8	3.7	40

Technical data:

Max. operating temperature: 120°C
 Min. operating temperature: -20°C
 Max. operating pressure: 16 bar

Material: DZR

Adapter

7708



Order number	Dim.
1 7708 86	M30 x 1.5

Adapter for HERZ Actuator, light gray for use with thermostatic valves M 30 x 1.5.

Flow diagram

Flow Diagram

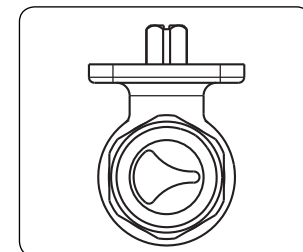
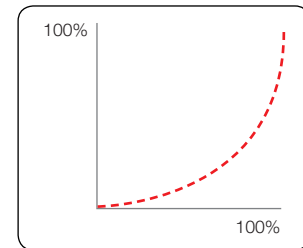
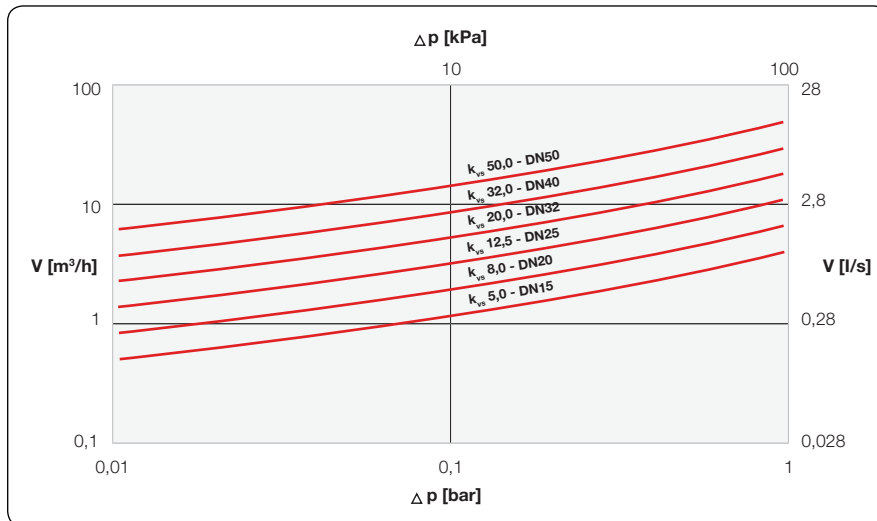

Description

The HERZ-control valve is characterized with high reliability and precision. The spindle of the ball valve is connected to the axle of the drive automatically. The ball is made of forged brass and regulates a linear flow in the control. This is realized by means of a profiled orifice in the ball. The seat seal is provided by a teflon collar sleeve insert. EPDM O-Rings are inserted behind these two sleeves. These O-Rings allow the ball and both collars a small axial movement, which realizes a high density and low torques. The spindle is sealed by two O-Rings. O-Rings can not be replaced.

Material

- Body forged brass (CW602N) acc. to EN 12420
- End connections forged brass (CW602N) acc. to EN 12420
- Ball pressed brass (CW602N), V-shape bore, machined to a microsmooth finish, chrome plated
- Ball seat Teflon (PTFE) with O-Ring (EPDM)
- Spindle brass (CW614N)
- Spindle sealing O-Ring double (EPDM)
- Spindle seat Teflon (PTFE)
- Connections Female threads acc. to ISO 7-1

Properties

HERZ two-port ball valve with internal thread for precise control, without leakage. Control ball valve for continuous control of cold water, hot water or air in closed circuits.

- Nominal pressure 40 bar
- Nominal size from DN15 to DN50
- Ball with equal percentage characteristic
- Spindle with large sliding surface and teflon sealing ring
- Highest ratio 500:1
- Low torque due to the collar sealed with O-Ring

Operating Data

- Maximum operating pressure PN 40 from DN15 to DN25, PN25 from DN32 to DN50
- Operating temperature - 10 °C to 110 °C
- Medium cold and hot water, water with max. 50% volume of glycol
- Angle of rotation (Spindle) 90° Torque (at nominal voltage): < 8 Nm



Control Ball Valve without handle

2117

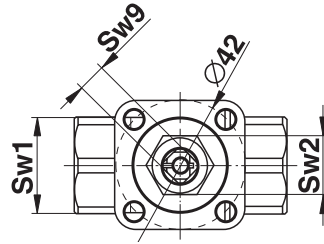
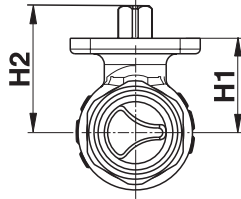
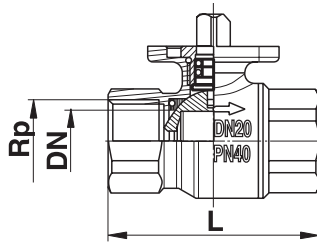

Order number	DN	PN	Rp	L	H1	H2	SW1	SW2	Kvs	
1 2117 01	15	40	1/2"	60	27,5	38	25	18	5	0.252
1 2117 02	20	40	3/4"	68	30,5	41	31	19	8	0.364
1 2117 03	25	40	1"	81	38	48,5	41	20	12.5	0.671
1 2117 04	32	25	1-1/4"	95	41,5	52	51	20	20	1.024
1 2117 05	40	25	1-1/2"	106	47	57,5	55	20	32	1.496
1 2117 06	50	25	2"	127	54,8	65,3	70	20	50	2.652

Specifications:

- Ball with equal percentage characteristic
- Body material: DZR
- Male thread to ISO 7/1 Rp
- O-ring: EPDM

HERZ-Rotary Actuator for 2-Port Control Ball Valves

7712



Order number	Type	Torque	Nominal voltage	Control
1 7712 33	Actuator for 2 / 3-Port Control Ball Valve	8 Nm	230 V / AC	2 / 3-point
1 7712 35	Actuator for 3-Port Control Mixing Valve	8 Nm	24 V / AC / DC	3-Point
1 7712 60	Actuator for 2 -Port Control Ball Valve	10 Nm	230 V / AC	Open / Close
1 7712 62	Actuator for 2-Port Control Ball Valve	10 Nm	24 V / AC	Modulating

Two-Port Flanged Valve

F 4035

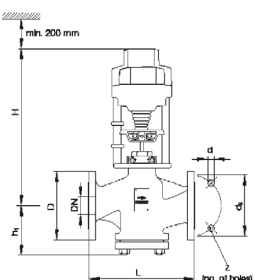
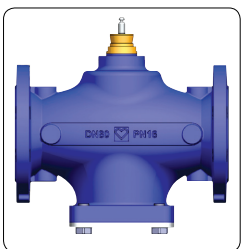

Order number		DN	Stroke [mm]	Kvs	D	L	z	d	d _k	h1	H	
PN 16	PN 25											
F 4035 01	F 4035 40	15	10	1	95	130	4	14	65	68	230	4.5
F 4035 11	F 4035 51	15	10	1.6	95	130	4	14	65	68	230	4.5
F 4035 21	F 4035 61	15	10	2.5	95	130	4	14	65	68	230	4.5
F 4035 31	F 4035 71	15	14	4	95	130	4	14	65	68	230	4.5
F 4035 03	F 4035 43	25	20	6.3	115	160	4	14	85	85	235	7.5
F 4035 13	F 4035 53	25	20	10	115	160	4	14	85	85	235	7.5
F 4035 04	F 4035 44	32	20	16	140	180	4	19	100	105	240	10.5
F 4035 05	F 4035 45	40	20	25	150	200	4	19	110	115	250	11
F 4035 16	F 4035 56	50	20	40	165	230	4	19	125	125	370	17.5
F 4035 07	F 4035 47	65	40	63	185	290	4	19	145	132	390	25
F 4035 08	F 4035 48	80	40	100	200	310	8	19	160	105	435	34
F 4035 09	F 4035 49	100	45	160	220	350	8	19	180	127	465	49
F 4035 10	F 4035 50	125	65	250	250	400	8	19	210	145	500	65
F 4035 41	F 4035 52	150	65	330	285	480	8	23	240	180	535	84

Specifications:

- Body material: **PN 16:** GG 25, flange according to EN 1092-2
PN 25: GGG 40.2, flange according to EN 1092-2
- Temperature range: 5°C to 140°C

Three-Port Mixing Valve with handle

2137

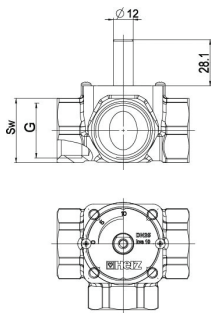

Materials:

- Body: forged brass (CW602N) according to EN 12420
- Ball: brass
- Sealing: EPDM (Gasket)

Technical data:

- Nominal pressure: 10 bar
- Operational temperature: -10 °C - 110 °C
- Short time op. temperature: 130 °C

Order number	DN	PN	Sw	G	Kvs	
1 2137 01	15	10	27	1/2"	4	0.403
1 2137 02	20	10	31	3/4"	6.3	0.447
1 2137 03	25	10	39	1"	10	0.790
1 2137 04	32	10	49	1-1/4"	16	1.041
1 2137 05	40	10	59	1-1/2"	25	1.712
1 2137 06	50	10	72	2"	40	2.585

Three-Port Mixing Valve with 3-Point Actuator (1 7712 25, 27)

2137



Order number	DN
1 2137 21	15
1 2137 22	20
1 2137 23	25
1 2137 24	32
1 2137 25	40

7712



Order number	Type	Torque	Nominal voltage	Control
1 7712 25	Actuator for 2 / 3-Port	10 Nm	230 V / AC	2 / 3-point
1 7712 27	Actuator for 2 / 3-Port	10 Nm	24 V / AC / DC	2 / 3-Point
1 7712 63	Actuator for 3-Point Control Mixing Valve	5 Nm	230 V / AC	3-Point

Four-Port Mixing Valve with handle (1 2100 95)

2138

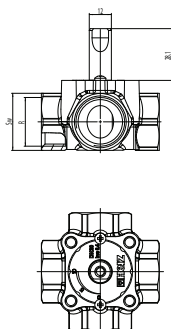

Order number	DN	Sw	G	Kvs	PN	
1 2138 01	15	27	1/2"	4	10	0.442
1 2138 02	20	31	3/4"	6,3	10	0.472
1 2138 03	25	39	1"	10	10	0.872
1 2138 04	32	49	1-1/4"	16	10	1.122

Female end connections,
Body and cone dezincification Brass
EPDM gasket. Medium temperature -10 °C – 110 °C
PN 10

Four-Port Mixing Valve with 3-Point Actuator (1 7712 25, 27)

2138

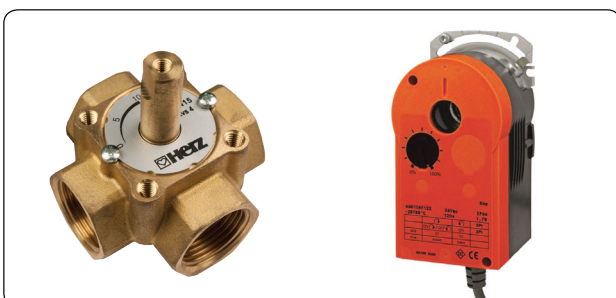

Order number	DN
1 2138 21	15
1 2138 22	20
1 2138 23	25
1 2138 24	32
1 2138 25	40
1 2138 26	50



Three-Port Mixing and Diverting Valve

4037

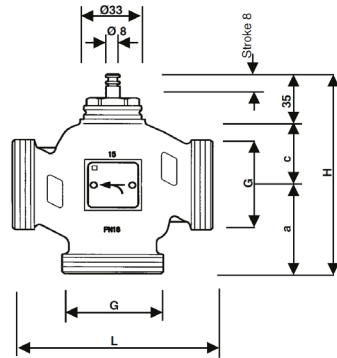

Max. operating temperature: -15 °C to 130 °C

Material: DZR

Order number	Dim.	G	a	c	L	H	dp max.	Kvs
1 4037 15	1/2	G3/4B	50	32	100	117	4 bar	4
1 4037 20	3/4	G1 B	50	33	100	118	3 bar	6.3
1 4037 25	1	G1 1/2B	55	36	110	126	2 bar	10
1 4037 32	1 1/4	G2B	60	38	120	133	1,5 bar	16
1 4037 40	1 1/2	G2 1/4B	70	48	130	153	1 bar	25
1 4037 50	2	G2 3/4B	75	54	150	164	0,8 bar	40

Three-Port Flanged Valve

F 4037

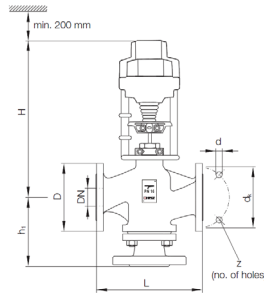

Technical data:

- Min. operating temperature: 5 °C
- Max. operating temperature: 140 °C
- Valve curve characteristic: equal percentage
- Type of connection: Flanges (EN 1092-2)
- Valve body material: GG 25
- Sealing material: FPM (ISO1629)
- Valve seat material: WN1.4021
- Valve cone material: up to DN 50 WN1.4021
from DN 65 to DN 150 GG 25/WN1.4021
- Stem material: WN1.4057

Order number PN 15	Order number PN 25	DN	PN	Stroke [mm]	Kvs	D	L	z	d	d _K	h ₁	H	📦
F 4037 01	F 4035 40	15	16	10	1	95	130	4	14	65	110	275	5
F 4037 11	F 4035 51	15	16	10	1.6	95	130	4	14	65	110	275	5
F 4037 21	F 4035 61	15	16	10	2.5	95	130	4	14	65	110	275	5
F 4037 31	F 4035 71	15	16	14	4	95	130	4	14	65	110	275	5
F 4037 03	F 4035 43	25	16	20	6.3	115	160	4	14	85	121	280	8
F 4037 13	F 4035 53	25	16	20	10	115	160	4	14	85	121	280	8
F 4037 04	F 4035 44	32	16	20	16	140	180	4	19	100	142	285	11.5
F 4037 05	F 4035 45	40	16	20	25	150	200	4	19	110	149	295	13
F 4037 16	F 4035 56	50	16	20	40	165	230	4	19	125	167	430	20
F 4037 07	F 4035 47	65	16	40	63	185	290	4	19	145	181	450	28
F 4037 08	F 4035 48	80	16	40	100	200	310	8	19	160	210	495	36
F 4037 09	F 4035 49	100	16	45	160	220	350	8	19	180	220	525	54
F 4037 10	F 4035 50	125	16	65	250	250	400	8	19	210	260	500	70
F 4037 41	F 4035 52	150	16	65	330	285	480	8	23	240	280	535	91

HVAC

Water

Gas

Valve Drives for Three-Port Valve, Actuating Power 500N

7712

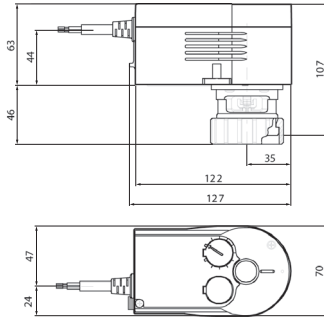

Technical data 1 7712 11

- Operation time 60 / 120 s
- Stroke 8 mm
- Pushing force 500 N
- Weight 0,7 kg
- Max. operating temperature 100 °C on valve body
- Ambient temperature -10 to 55 °C
- Ambient humidity 5 to 95% r.F.
- Electrical protection IP 54 (EN 60529)
- Control signal 0 to 10 V, Rj >100 kOhm
- Positional feedback signal 0 to 10 V, load > 10 kOhm
- Starting point U0 0 to 10 V
- Power consumption 60 s 120 s
- Response time 200 ms

Technical data 1 7712 50/51

- Operation time 120 s
- Stroke 8 mm
- Pushing force 500 N
- Weight 0,7 kg
- Max. operating temperature 100 °C on valve body
- Ambient temperature -10 to 55 °C
- Ambient humidity 5 to 95% r.F.
- Electrical protection IP 54 (EN 60529)
- Power consumption 120 s
- Response time 100 ms

Order number	Type	Nominal voltage	
1 7712 11	Actuation of three-way valves	24V	For controllers with continuous output (0...10 V) or switching output (2-point or 3-point control)
1 7712 50	Actuation of three-way valves	230V	For controllers with a switching output (2/3-point control).
1 7712 51	Actuation of three-way valves	24V	For controllers with a switching output (2/3-point control)

Handwheel for Three-Port Mixing and Diverting Valves

9102

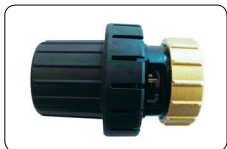

Order number

1 9102 40

HERZ-Hand Wheel for HERZ-Three-Port Mixing and Diverting Valve 4037, not supplied with valve drive.



Order number

1 4006 02

Adjusting Key

for HERZ-Flow controller 4001, used from 2009
for HERZ-Differential pressure controller 4002, used from 2009
for HERZ-Combi Valve 4006



Pressure Independent Balancing Control Valve

4006

4206

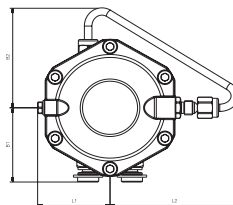
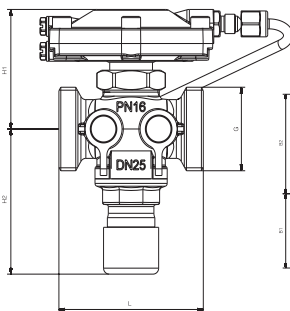
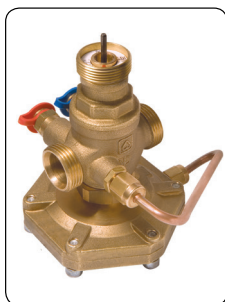

Technical data:

- Min. operating temp.: - 20 °C (frost protection)
- Max. operating temp.: up to 130 °C

Material:

- Body: DZR
- Membranes and O-rings: EPDM

Order number PN16	Order number PN25	DN	I/h	L	H1	H2	H2 + Actuator	B1	B2	L1	L2	M	Test points
1 4006 11	1 4206 11	15	40-800	66	59	73	132	49	63	48	81	28 x 1.5	yes
1 4006 12	1 4206 12	20	80-900	76	60	73	132	51	68.5	48	85	28 x 1.5	yes
1 4006 13	1 4206 13	25	100-1900	76	60	73	132	51	68.5	48	85	28 x 1.5	yes
1 4006 14	1 4206 14	32	200-2500	114	76	86	143	76	47	57	89	28 x 1.5	yes
1 4006 15	1 4206 15	40	400-4000	132	86	95	154	75	47	70	81	28 x 1.5	yes
1 4006 16	1 4206 16	50	500-5000	140	86	95	154	75	47	70	81	28 x 1.5	yes
1 4006 41	1 4206 41	15	40-800	66	59	73	132	49	63	48	81	28 x 1.5	no
1 4006 42	1 4206 42	20	80-900	76	60	73	132	51	68.5	48	85	28 x 1.5	no
1 4006 43	1 4206 43	25	100-1900	76	60	73	132	51	68.5	48	85	28 x 1.5	no
1 4006 44	1 4206 44	32	200-2500	114	76	86	143	76	47	57	89	28 x 1.5	no
1 4006 45	1 4206 45	40	400-4000	132	86	95	154	75	47	70	81	28 x 1.5	no
1 4006 46	1 4206 46	50	500-5000	140	86	95	154	75	47	70	81	28 x 1.5	no

SMART Pressure Independent Balancing Control Valve

4006 SMART

4206 SMART

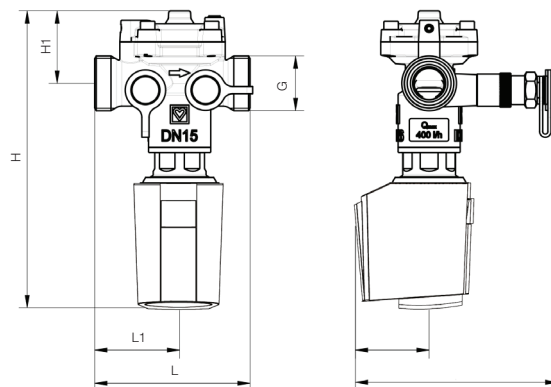

Technical data:

- Min. operating temp.: - 20 °C
- Max. operating temp.: up to 130 °C

Material:

- Body: DZR
- Membranes and O-rings: EPDM

Order number PN16	Order number PN25	DN	I/h	L	L1	B	B1	H	H + Actuator	H1	Test points
1 4006 20	1 4206 20	15 LF	20-100	75	41	85	24	104	154	36	yes
1 4006 21	1 4206 21	15	80-400	75	41	85	24	104	154	36	yes
1 4006 22	1 4206 22	20	200-800	75	41	85	24	105	155	33	yes
1 4006 29	1 4206 29	15 MF	40-200	75	41	85	24	104	154	36	yes
1 4006 60	1 4206 60	15 LF	20-100	75	41	50	24	104	154	36	no
1 4006 61	1 4206 61	15	80-400	75	41	50	24	104	154	36	no
1 4006 62	1 4206 62	20	200-800	75	41	50	24	105	155	33	no
1 4006 69	1 4206 69	15 MF	40-200	75	41	50	24	104	154	36	no

Actuating Drives for 2-point control

7708



Order number	Type	Supply voltage	Dim.	Stroke [mm]	Adapter	Cable	End switch	Actuating force	Power consumption
1 7708 52	NC	24V	M28 x 1.5	5	M28 x 1.5 (red)	fix	no	100 N	1 W
1 7708 53	NC	230V	M28 x 1.5	5	M28 x 1.5 (red)	fix	no	100 N	1 W
1 7708 24	NO	230V	M28 x 1.5	5	M28 x 1.5 (red)	fix	no	100 N	1 W



Order number	Type	Supply voltage	Dim.	Stroke [mm]	Adapter	Cable	End switch	Actuating force	Power consumption
1 7708 66	NC	230V	M28 x 1.5	4	M28 x 1.5 (red)	fix	no	100 N	2 W
1 7708 68	NC	24V	M28 x 1.5	4	M28 x 1.5 (red)	fix	no	100 N	2 W

DDC Actuating Drives

7990



Order number	Type	Supply voltage	Dim.	Stroke [mm]	Adapter	Cable	End switch	Actuating force	Power cons.
1 7990 31	NC	24V control signal 0 - 10 V	M28 x 1.5	5	M28 x 1.5 (blue)	plug-in	no	125 N	1.2 W
1 7990 32	NC	24V control signal 0 - 10 V	M28 x 1.5	5	M28 x 1.5 (blue)	plug-in	no	125 N	1.2 W

Motoric Valve Drive

7708



Order number	Type	Control	Supply voltage	Dim.	Stroke [mm]	Adapter	Actuating force
1 7708 40	NC	3-point	24V	M28 x 1.5	8.5	M28 x 1.5 (blue)	200 N
1 7708 41	NC	3-point	230V	M28 x 1.5	5	M28 x 1.5 (blue)	200 N
1 7708 42	NC	0-10 V DC signal	24V	M28 x 1.5	8.5	M28 x 1.5 (blue)	200 N
1 7708 46	NC	0-10 V DC signal	24V	M28 x 1.5	8.5	M28 x 1.5 (blue)	200 N
5 7712 08	NC	0-10 V DC signal	24 V	M28 x 1.5	8.5	M28 x 1.5 (blue)	120 N



Flanged Flow Controller with integrated Control valve

F 4006

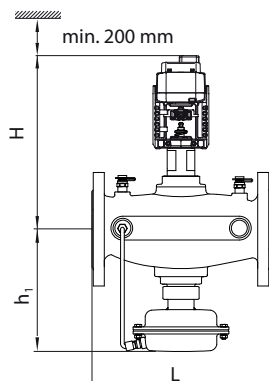

Technical data:

Diff. pressure across the restrictor 0,2 bar
 Min. operating temperature - 20 °C
 Max. operating temperature 110 °C

Type of connection Flanged (EN 1092-2)
 Valve body material EN-GJL-250
 Gasket material EPDM
 Cones, stem, seat material CW617N-R320-S, WN1.4305, WN1.4305
 Impulse tupe WN1.4301
 Diaphragm material EPDM

Order number PN 16	Order number PN 25	DN	Stroke [mm]	min. Flowrate @ 25% [m³/h]	max. Flowrate @ 100% [m³/h]	mind. dp [kPa]	H	h1	L
F 4006 62	F 4006 96	50	15	3.75	15	40	295	210	230
F 4006 63	F 4006 97	65	15	5	20	40	295	210	290
F 4006 64	F 4006 98	80	20	9	36	40	332	230	310
F 4006 65	F 4006 99	100	20	10.75	43	40	332	232	350
F 4006 66	F 4006 10	125	40	25	90	40	520	410	400
F 4006 56	-	125 HF	40	37.5	120	70	480	480	400
F 4006 67	F 4006 11	150	40	36.25	145	40	520	380	480
F 4006 57	-	150 HF	40	50	175	70	520	380	480
F 4006 68	F 4006 12	200	40	52.5	190	40	558	560	600
F 4006 58	-	200 HF	40	75	250	70	558	560	600

Actuators for control valves, modulating (for 2-port, 3-way and PICV)

7712



Order number	Nominal voltage	Actuating force	Stroke [mm]	Operating time	Degree of protection IEC/EN
1 7712 28	230 V / AC	500 N	8- 20	7.5 s / mm	IP54
1 7712 29	AC/DC 24 V	500 N	8- 20	7.5 s / mm	IP54



Order number	Nominal voltage	Actuating force	Stroke [mm]	Operating time	Degree of protection IEC/EN
1 7712 30	230 V / AC	1000 N	20	6 s / mm	IP66
1 7712 31	AC/DC 24 V	1000 N	20	6 s / mm	IP66



Order number	Nominal voltage	Actuating force	Stroke [mm]	Operating time	Degree of protection IEC/EN
1 7712 21	24 V / AC / DC	2500 N	49	2/4/6 s / mm	IP66
1 7712 32	24 V / AC / DC	2500 N	49	2/4/6 s / mm	IP66

Actuators for control valves, open-close, 3-point (for 2-port, 3-way and PICV)

F 7712



Order number	Nominal voltage	Type	Actuating force	Stroke [mm]	Position indication	Actuating time	Degree of protection IEC/EN
F 7712 95	AC/DC 24 V	open-close 3-point	500 N	15	mechanical 5 - 15 mm stroke	150 s	IP54
F 7712 96	AC/DC 24 V	open-close 3-point	1000 N	20	mechanical 5 - 20 mm stroke	150 s	IP54
F 7712 97	AC/DC 24 V	open-close 3-point	1500 N	20	mechanical 5 - 20 mm stroke	150 s	IP54
F 7712 98	AC/DC 24 V	open-close 3-point	2500 N	40	mechanical 5 - 40 mm stroke	150 s	IP54
F 7712 81	AC 230 V	open-close 3-point	500 N	15	mechanical 5 - 15 mm stroke	150 s	IP54
F 7712 82	AC 230 V	open-close 3-point	1000 N	20	mechanical 5 - 20 mm stroke	150 s	IP54
F 7712 83	AC 230 V	open-close 3-point	1500 N	20	mechanical 5 - 20 mm stroke	150 s	IP54
F 7712 84	AC 230 V	open-close 3-point	2500 N	40	mechanical 5 - 40 mm stroke	150 s	IP54



Actuators for control valves, modulating (for 2-port, 3-way and PICV)

F 7712

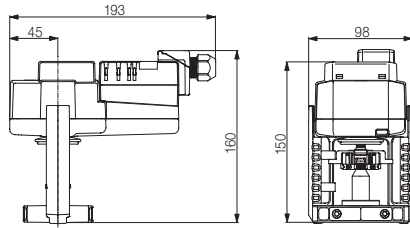

Order number	Nominal voltage	Type	Actuating force	Stroke [mm]	Operating range	Position feedback	Actuating time	Degree of protection IEC/EN
F 7712 90	AC/DC 24 V	modulating	500 N	15	DC 0 (2) - 10 V	DC 0 (2) - 10 V	150 s	IP54
F 7712 91	AC/DC 24 V	modulating	1000 N	20	DC 0 (2) - 10 V	DC 0 (2) - 10 V	150 s	IP54
F 7712 92	AC/DC 24 V	modulating	2500 N	40	DC 0 (2) - 10 V	DC 0 (2) - 10 V	150 s	IP54
F 7712 93	AC/DC 24 V	modulating	1500 N	10	DC 0 (2) - 10 V	DC 0 (2) - 10 V	150 s	IP54
F 7712 94	AC 24 V	modulating	12000 N	65	DC 0 (2) - 10 V	DC 0 (2) - 10 V	0.8 s/mm	IP65

Fixed Orifice Double Regulating Valve with two test points

4017 M

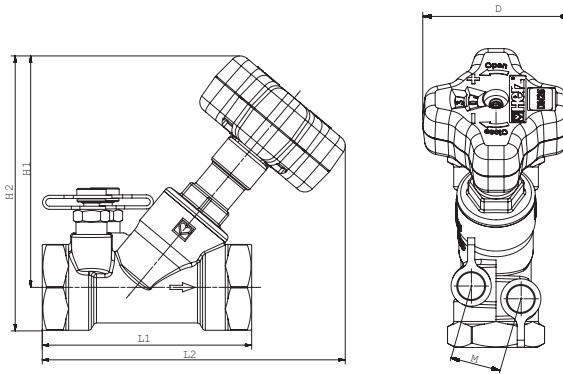

Technical data:

- Max. operating temperature 130 °C
- Max. operating pressure 20 bar
- Max. differential pressure at closed valve 10 bar

- body: DZR
- non-rising stem sealed with Double-O-Ring
- presetting through stroke limiting,
- handwheel with presetting digital display

Order number	DN	L1	L2	H1	H2	M	D	Kvs valve	Kvs Orifice
1 4017 01	15 LF	83	129	96	109	25	70	0.46	0.48
1 4017 11	15 MF	83	129	96	109	25	70	0.88	0.97
1 4017 21	15	83	129	96	109	25	70	2.00	1.95
1 4017 02	20	91	135	99	115	25	70	3.60	3.95
1 4017 03	25	110	146	109	130	25	70	6.50	7.90
1 4017 04	32	122	159	117	142	25	70	13.30	15.75
1 4017 05	40	135	178	136	163	25	70	18.50	21.50
1 4017 06	50	164	197	140	175	25	70	33.00	46.70

Fixed Orifice Double Regulating Valve with capillary connection

4017 ML



Order number	DN	L1	L2	H1	H2	M	D	Kvs valve	Kvs Orifice
1 4017 30	15 LF	83	129	96	109	25	70	0.46	0.48
1 4017 39	15 MF	83	129	96	109	25	70	0.88	0.97
1 4017 31	15	83	129	96	109	25	70	2.00	1.95
1 4017 32	20	91	135	99	115	25	70	3.60	3.95
1 4017 33	25	110	146	109	130	25	70	6.50	7.90
1 4017 34	32	122	159	117	142	25	70	13.30	15.75
1 4017 35	40	135	178	136	163	25	70	18.50	21.50
1 4017 36	50	164	197	140	175	25	70	33.00	46.70

Variable Orifice Double Regulating Valve, Straight model

4217 GM STRÖMAX

4217 GR STRÖMAX

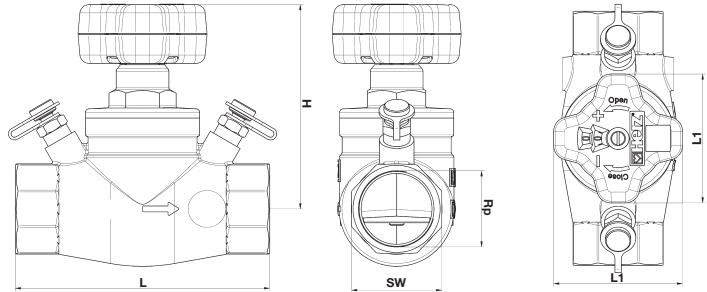

Order number	DN	Rp	L	L1	H	SW hexagon	SW octagon	Kvs	Test point
1 4217 30	15 LF	1/2	100	71	97	27		0.93	Yes
1 4217 31	15 MF	1/2	100	71	97	27		3.49	Yes
1 4217 01	15	1/2	100	71	97	27		6.05	Yes
1 4217 32	20	3/4	100	71	97	32		6.11	Yes
1 4217 33	25	1	120	71	107	41		9.22	Yes
1 4217 34	32	1 1/4	140	71	112		50	18.83	
1 4217 35	40	1 1/2	150	71	112		55	23.29	
1 4217 36	50	2	165	110	136		70	35.26	
1 4217 07	65	2 1/2	190	110	141		85	52.11	
1 4217 08	80	3	210	110	142		100	76.10	

Variable Orifice Double Regulating Valve, Straight model with capillary connection

4217 GML STRÖMAX

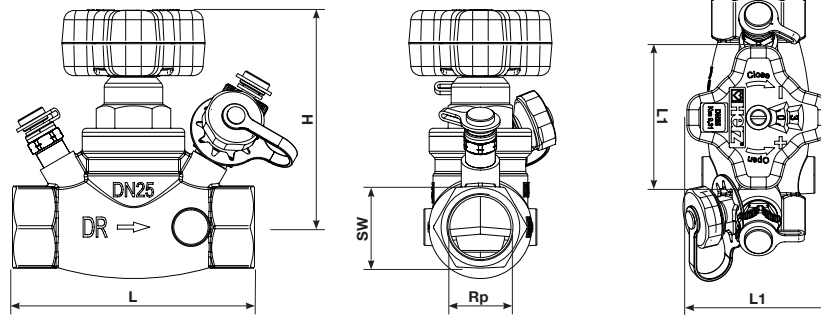

Order number	DN	Rp	L	L1	H	SW hexagon	SW octagon	Kvs
1 4217 10	15 LF	1/2	100	71	97	27		0.93
1 4217 19	15 MF	1/2	100	71	97	27		3.49
1 4217 11	15	1/2	100	71	97	27		6.05
1 4217 12	20	3/4	100	71	97	32		6.11
1 4217 13	25	1	120	71	107	41		9.22
1 4217 14	32	1 1/4	140	71	112		50	18.83
1 4217 15	40	1 1/2	150	71	112		55	23.29
1 4217 16	50	2	165	110	136		70	35.26
1 4217 17	65	2 1/2	190	110	141		85	52.11
1 4217 18	80	3	210	110	142		100	76.10



Inclined Shut-off Valve With Non-Rising Spindle

4125 STRÖMAX-D



4125 STRÖMAX-AD WITH BORES FOR DRAINING

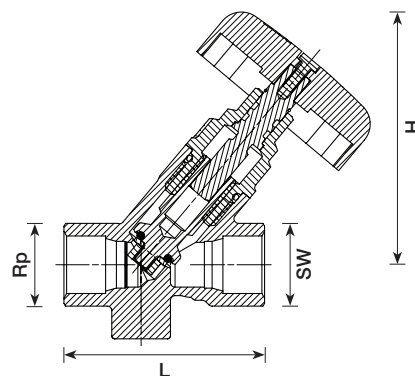
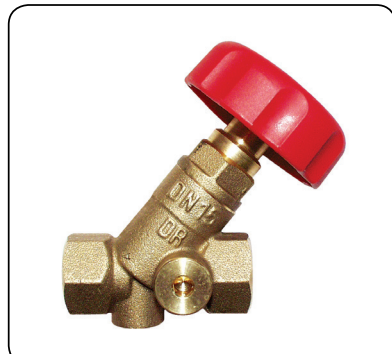

Order number	DN	Rp	L	H	SW hexagon	SW octagon	Kvs
1 4125 61	15	1/2	65	86	27		4.8
1 4125 62	20	3/4	75	92	32		11.5
1 4125 63	25	1	90	105	41		21.5
1 4125 64	32	1 1/4	110	118		50	35.0
1 4125 65	40	1 1/2	120	127		55	48.0
1 4125 66	50	2	150	155		70	82.0
1 4125 67	65	2 1/2	180	205		85	127.0
1 4125 68	80	3	210	226		100	183.0

Technical Data

Max. operation temperature: 110°C
 Max. operation pressure: 20 bar
 Max. differential pressure on closed seat: 10 bar

Body: casted DZR brass CC752S
 Upper part: DZR brass CW602N
 Cone: DZR brass CW602N
 Spindle brass CW617N
 Sealing: EPDM
 Hand wheel: Polyamide

Drain possibility: 1 4125 71-78

Inclined Shut-off Valve With Rising Spindle

4115 STRÖMAX



4115 STRÖMAX-A WITH BORES FOR DRAINING

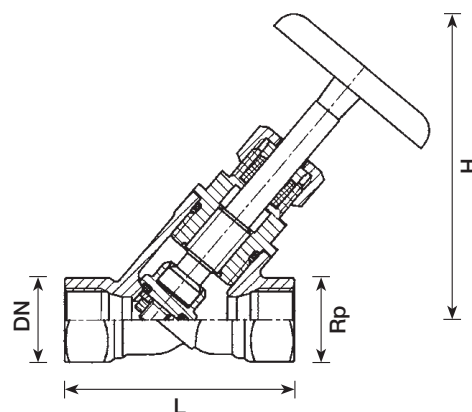
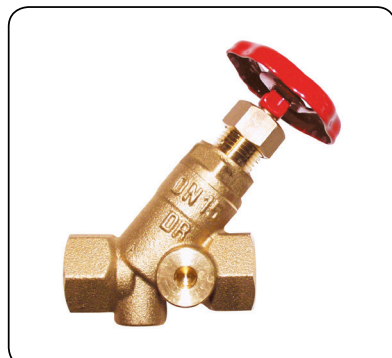

Order number	DN	Rp	L	H _{open}	Kvs
1 4115 00	10	3/8	60	85	3.0
1 4115 01	15	1/2	65	90	4.0
1 4115 02	20	3/4	75	115	10.5
1 4115 03	25	1	90	130	18.0
1 4115 04	32	1 1/4	110	156	32.5
1 4115 05	40	1 1/2	120	175	44.0
1 4115 06	50	2	150	215	82.0
1 4115 07	65	2 1/2	180	297	127.0
1 4115 08	80	3	210	325	183.0

Technical Data

Max. operation temperature: 110°C
 Max. operation pressure: 20 bar
 Max. differential pressure on closed seat: 10 bar

Body: casted DZR brass CC752S
 Upper part: DZR brass CW602N
 Cone: DZR brass CW602N
 Spindle: brass CW617N
 Sealing: EPDM
 Hand wheel: sheet steel

Drain possibility: 1 4115 11-18

Circuit Regulating Valves for Differential Pressure Measurement, flanged version

4218 GF

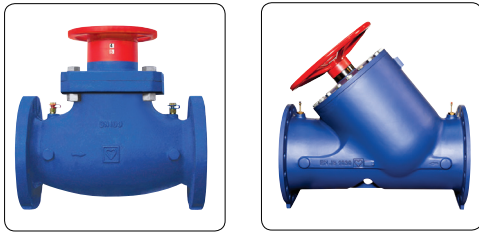

STRÖMAX-GF-circuit regulating valve with test points, DN 50 - 300 Screw-down model, grey cast iron body GJL 250 acc. EN 1561, flange acc. EN 1092, PN 16, blue enamel coating. Upper part grey cast iron GJL 250, with non-rising spindle, spindle seal by means of triple O-Ring. Presetting step is shown on the digital display.

Order number PN16	Order number PN25	DN	L	H1	H2	D	Kvs	
1 4218 80	1 4220 80	50	230	169	252	150	49	16.8
1 4218 81	1 4220 81	65	290	186	280	150	75	23.6
1 4218 82	1 4220 82	80	310	208	308	175	110	30
1 4218 83	1 4220 83	100	350	235	345	175	165	38
1 4218 84	1 4220 84	125	400	260	385	265	241	63
1 4218 85	1 4220 85	150	480	308	451	265	372	88
1 4218 86	1 4220 86	200	600	449	619	450	704	161
1 4218 87	1 4220 87	250	730	503	705	450	812	256
1 4218 88	1 4220 88	300	852	562	842	450	1383	383
1 4218 89	1 4220 89	350	980	758	1021	520	643	536
1 4218 90	1 4220 90	400	1100	805	1103	580	643	547
1 4218 92	1 4220 92	500	1250	1051	1413	715	1034	968

Shutoff Valve, flanged version

4218 AGF



Order number PN 15	Order number PN25	DN	Dim.	Kvs
1 4218 53	1 4220 53	25	1	11.0
1 4218 54	1 4220 54	32	1 1/4	20.1
1 4218 55	1 4220 55	40	1 1/2	30.4
1 4218 56	1 4220 56	50	2	36.9
1 4218 57	1 4220 57	65	2 1/3	62.5
1 4218 58	1 4220 58	80	3	75.0

STRÖMAX-AGF-Shutoff Valve, flanged version

Body made of cast iron GJL 250 according to EN 1561, flange according to EN 1092, PN 25; length according to ÖNORM EN-558-1, basic series 1, blue enamel coating. Valve upper part made of brass. Non-rising spindle, spindle seal by means of double O-Ring. A permanently elastic soft seal is used as a seat seal.

Circuit Regulating Valves for Differential Pressure Measurement, flanged version

4218 GMF

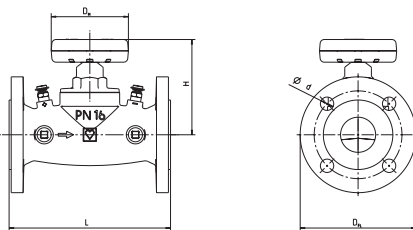

Order number PN 16	Order number PN 25	DN	L	H	DH	DFL	d	Kvs
1 4218 46	1 4220 46	50	230	135	110	165	19	37.84
1 4218 47	1 4220 47	65	290	145	110	185	19	60.3
1 4218 48	1 4220 48	80	310	145	110	200	19	67.8
1 4218 49	1 4220 49	100	350	190	190	220	19	99.55
1 4218 50	1 4220 50	125	400	230	190	250	19	186.58
1 4218 51	1 4220 51	150	480	264	190	285	23	279.05

4218 GMF STRÖMAX-GMF circuit regulating valve with test points DN 25 - 150

Screw-down model, body made of cast iron GJL 250, according to EN 1561, flange according to EN 1092, PN 16, blue coating. Brass upper part, screwed, with non-rising spindle, spindle seal by means of double O-Ring. Presetting by limitation of valve lift and inside spindle. Pre-setting step is shown on the digital display in the hand wheel window. Two quick measuring valves are mounted next to hand wheel. Four bores for draining fittings, closed with screw plugs 3/8 (DN10).



Metering Station with two test points

4000

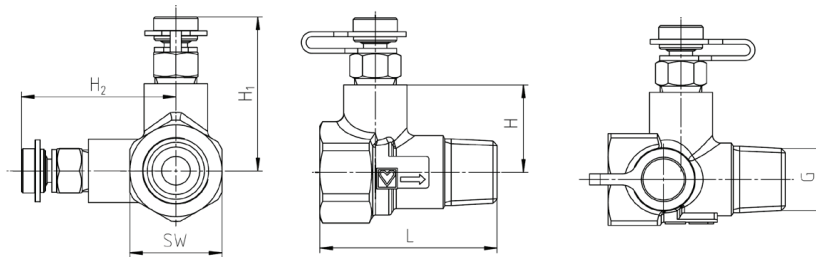
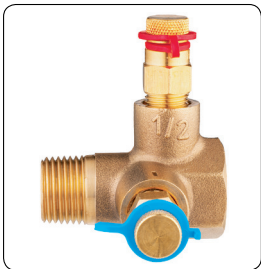

Order number	DN	G	L	H1	H2, H3	SW	Kvs	PN
1 4000 11	15 LF	1/2	56	27.5	52	29	0.55	20
1 4000 21	15 MF	1/2	56	27.5	52	29	1.10	20
1 4000 01	15	1/2	56	27.5	52	29	2.20	20
1 4000 02	20	3/4	58	30	54.5	36	4.25	20
1 4000 03	25	1	64	33	57.5	43	8.60	20
1 4000 04	32	1 1/4	72	38.5	63	53	15.90	20
1 4000 05	40	1 1/2	72	40	64.5	61	23.70	20
1 4000 06	50	2	80	45	69.5	72	48.00	20

Flow Measuring Orifice Plate

4000

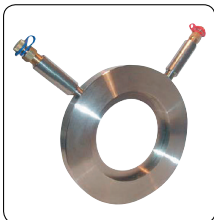

Order number	PN25	DN	Kvs
1 4000 31	5 4000 81	65	100.7
1 4000 32	5 4000 82	80	133.8
1 4000 33	5 4000 83	100	237.7
1 4000 34	5 4000 84	125	339
1 4000 35	5 4000 85	150	511
1 4000 36	5 4000 86	200	858
1 4000 37	5 4000 87	250	1235
1 4000 38	5 4000 88	300	1793
1 4000 39	5 4000 89	350	1995
1 4000 40	5 4000 90	400	2334
1 4000 41	5 4000 91	450	2981
1 4000 42	5 4000 92	500	3700
1 4000 43	5 4000 93	600	4491

Stainless steel disc with extended test points
 Maximum working temperature 120 °C
 Kv-values, also pressure and temperature ratings, comply with requirements of BS7350
 Kv-values in m3/hour at a pressure drop of 1 bar

Foot valve



Order number	DN	PN
1 0237 01	15	25
1 0237 02	20	25
1 0237 03	25	25
1 0237 04	32	25
1 0237 05	40	25
1 0237 06	50	25

Foot valve with stainless steel filter

Technical data

- Operating pressure: depending on dimension, see table above
- Operating temperature range: -10°C to 110°C (water 0.5°C - 95°C, no steam)
- Medium: water, compressed air ... (non-aggressive mediums)

Measuring valves

0284



Order number	Dim.
1 0284 01	1/4

Test points for HERZ-STRÖMAX-Circuit regulating valves (manufactured from 2004), brass version, blue cap (return) for flow computer.



Order number	Dim.
1 0284 02	1/4

Test points for HERZ-STRÖMAX-Circuit regulating valves (manufactured in 2004 or later), brass version, red cap (flow) for flow computer.



Order number	Dim.
2 0284 01	1/4

Test points for HERZ-STRÖMAX-TW-Circuit regulating valves Brass version, blue cap (return) for flow computer, valves are marked in green (for drinking water).



Order number	Dim.
2 0284 02	1/4

Test points for HERZ-STRÖMAX-TW-Circuit regulating valves Brass version, red cap (flow) for flow computer, valves are marked in green (for drinking water).



Order number	Dim.
1 0284 11	1/4

Test points for HERZ-STRÖMAX-Circuit regulating valves Brass version, blue cap (return) for flow computer. Extended model for insulated valves.



Order number	Dim.
1 0284 12	1/4

Test points for HERZ-STRÖMAX-Circuit regulating valves. Brass version, red cap (flow) for flow computer. Extended model for insulated valves.



Order number	Dim.
1 0284 21	1/4

Test points with draining function Brass version, blue cap, with swivel hose connection. Test point for flow computer.



Order number	Dim.
1 0284 22	1/4

Test points with draining function Brass version, red cap, with swivel hose connection. Test point for flow computer.



Order number	Dim.
1 0284 23	1/4

Extended test point, drain function, blue cap.

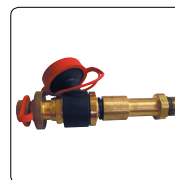

Order number	Dim.
1 0284 24	1/4

Extended test point, drain function, red cap.



Order number	Dim.
1 0284 03	1/4

Test points with capillary connection brass version, blue cap (return).



Order number	Dim.
1 0284 04	1/4

Test points with capillary connection brass version, red cap (supply).



Accessories for Measuring Computer

0284



1 0284 00 Test point adaptors

Order number
1 0284 00



1 0284 10 Measuring valve

1 set = 2 pieces.

Order number
1 0284 10

8900



Filter replacement set and seals

Set contains of 2 filters and 2 sealings for measuring hoses to measuring computer 1 8900 04.

Order number
1 8900 10

Capillary for Differential Pressure Controllers 4007

4002, 4007



Ball valve with nipple

Order number	Dim.
1 4007 78	1/8

Capillary for Differential Pressure Controller with ball valve 1/8

Order number	Dim.
1 4002 78	1.0 m

4002, 4007



Capillary for Differential Pressure Controller with screw plug G 1/4 and nipples 1/8 G x 1/4 G

Order number	Dim.
1 4007 79	1.0 m
1 4007 80	1.5 m
1 4002 80	2.0 m



Order number	DN
1 4218 22	50-65
1 4218 23	80-100
1 4218 24	125-150
1 4218 25	200-250
1 4218 26	300

Measuring Computer

8900



1 8900 04 Measuring computer for differential pressure

Electronic differential pressure gauge for one-handed operation with integral pressure transducer for the measurement at balancing valves with direct display and display of flow and the differential pressure. Measuring range 0–10 bar, max. Pressure 12 bar, connection for printer or PC via USB interface, IP 65, recording memory for 20,000 measurements. Delivered with accessories: 2 measuring hoses with quick-on stops and filter hose adapter, software and user manual on CD, measuring set 1 0284 00 and extension lead for measuring valve 1 0284 10 Power supply Li/ion battery, operation time 12 hrs. It is recommended to provide annual maintenance and calibration!

Power supply	Display	Software	Data memory	Temperature	Measuring range	Calibration	Verification	Measurement method
3V Li/ion battery 950 mAhrs, 12 hrs operating time, 1 year Stand-By, charging with supply unit 230 V~ or USB port	44x33 mm, il- luminated, 240x320 pixel RGB, 65k colors	Update only by manufac- turer	20000 meas- ure- ments can be stored	Ambient: -5 - 50 °C Medium: -5 - 90 °C Storage: -5 - +50 °C hoses can freeze	Max. pressure: 12 bar Differential pressure: 10 bar Static pressure: n.a.	once daily before the meas- ure- ments, done by pressing the „ZERO“ key without connected test hoses	possible and recom- mended by manufacturer, validity 1 year	Output flow rate and dp, valve type, settings, medium

Differential Pressure Overflow Valve

4004

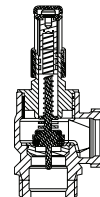
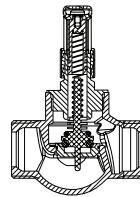
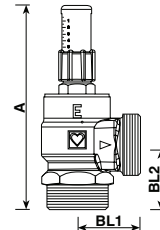
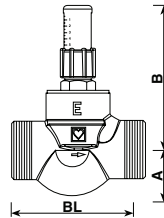

Order number	Dim.	Model	Threaded connection	A	B	BL	BL1	BL2	Kvs
1 4004 31	DN 15	straight	G 3/4 B ISO 228/1	26	82	69.5	-	-	2.2
1 4004 32	DN 20	straight	G 1 B ISO 228/1	26	82	75	-	-	2.2
1 4004 41	DN 15	angle	G 3/4 B ISO 228/1	101	-	-	32	25	2.2
1 4004 42	DN 20	angle	G 1 B ISO 228/1	111	-	-	34	34.5	2.2



Differential Pressure Controller, flanged version

F 4007 01 - 08

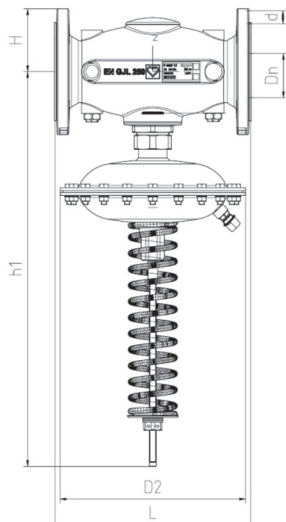

Order number	DN	L [mm]	h1 [mm]	H [mm]	d [mm]	D2 [mm]	dp setting range [kPa]
F 4007 07	65	290	581	93	19	275	10-40
F 4007 17	65	290	581	93	19	275	20-80
F 4007 27	65	290	567	93	19	156	50-150
F 4007 08	80	310	603	113	19	275	10-40
F 4007 18	80	310	603	113	19	275	20-80
F 4007 28	80	310	588	113	19	156	50-150
F 4007 09	100	350	603	112	19	275	10-40
F 4007 19	100	350	603	112	19	275	20-80
F 4007 29	100	350	588	112	19	156	50-150
F 4007 10	125	400	727	181	19	275	10-40
F 4007 20	125	400	727	181	19	275	20-80
F 4007 30	125	400	727	181	19	275	50-150
F 4007 11	150	480	721	185	23	275	10-40
F 4007 21	150	480	721	185	23	275	20-80
F 4007 31	150	480	721	185	23	275	50-150

Technical data

- Max. working pressure: 16 bar
- Testing pressure: 25 bar
- Max. differential pressure over the valve: 4 bar
- Max. allowed working temperature: 110 °C
- Min. working temperature: -10 °C

- Valve body material: EN-GJL-250 acc. to EN 1561
- Type of connection: Flange (EN 1092-2)
- Diaphragm: EPDM with textil
- O-Ring: EPDM
- Spring: EN 10270-1-SH

Differential Pressure Controller (DPCV)

4002

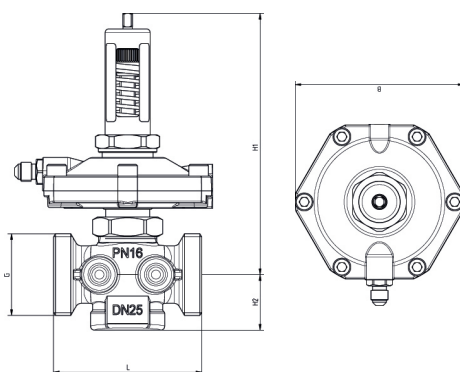

Material:

- Body: DZR brass
- Membranes and O-rings: EPDM

Technical data:

- Max. operating pressure: 16 / 25 bar
- Min. operating temp.: - 20 °C
- Max. operating temp.: 120 °C

Order number	Regulating range	DN	G	I/h	L	H1	H2	B	B1	B2	Kvs
1 4002 41	5-30 kPa	15	3/4 G	50-1300	66	133	28	95	26	29	2.66
1 4002 42	5-30 kPa	20	1 G	100-1600	76	134	29	95	28	28	4.36
1 4002 43	5-30 kPa	25	1 1/4 flatsealing	150-2000	76	134	29	95	28	28	5.38
1 4002 44	5-30 kPa	32	1 1/2 flatsealing	200-5000	114	150	47	95	-	-	9.48
1 4002 45	5-30 kPa	40	1 3/4 flatsealing	400-8000	132	160	55	95	-	-	14.95
1 4002 46	5-30 kPa	50	2 3/8 flatsealing	400-9000	140	160	55	94	-	-	14.95
1 4002 61	25-60 kPa	15	3/4 G	50-1300	66	133	28	95	26	29	2.66
1 4002 62	25-60 kPa	20	1 G	100-1600	76	134	29	95	28	28	4.36
1 4002 63	25-60 kPa	25	1 1/4 flatsealing	150-2200	76	134	29	95	28	28	5.38
1 4002 64	25-60 kPa	32	1 1/2 flatsealing	200-7500	114	150	47	95	-	-	9.48
1 4002 65	25-60 kPa	40	1 3/4 flatsealing	500-9000	132	160	55	95	-	-	14.95
1 4002 66	25-60 kPa	50	2 3/8 flatsealing	500-10000	140	160	55	94	-	-	14.95

Butterfly Valve, semi lugged version

4219 ZF

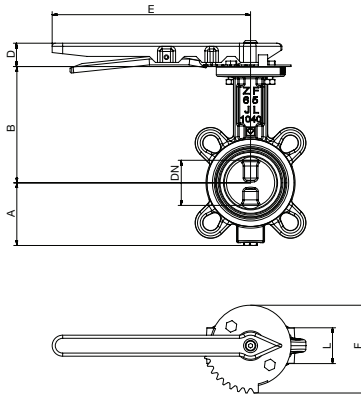

Materials

- Housing: GG, GJL-250/JL1040, according to EN1561
- Disc: stainless steel 1.4408
- Spindle: stainless steel ASTM-A276 / Type 316
- Lever DN50-150: steel, ST14.03
- Lever DN200-300: steel, S235 DIN2458/1626
- Housing sealing: EPDM according to ISO 1691
- O-Ring: EPDM according to ISO 1691
- Flange: according to EN1092-2

Technical data

- Max. operating temp.: 110°C
- Min. operating temp.: -20°C

Order number	DN	PN10	PN16	PN25	A	B	L	D	E	F		Torque
1 4219 01	50	+	+	+	68	125	43	30	255	112	3.8	20
1 4219 02	65	+	+	+	80	150	46	30	255	112	4	20
1 4219 03	80	+	+	+	87	157	46	30	255	112	4.7	25
1 4219 04	100	+	+	+	102	182	52	30	255	112	6.3	50
1 4219 05	125	+	+	+	120	201	56	30	255	112	8.3	50
1 4219 06	150	+	+	+	132	214	56	30	255	112	10.1	90
1 4219 07	200	-	+	+	167	245	60	95	365	88	16.6	150
1 4219 48	250		+	+	197	283	68	133	519	130	24.5	250
1 4219 49	300		+	+	222	308	78	133	519	130	37.6	350
4 4219 10	350		+	+	277	388	92				49	
4 4219 11	400		+	+	308	416	102				90	
4 4219 12	450		+	+	342	455	114				110	
4 4219 13	500		+	+	374	490	127				150	
4 4219 14	600		+	+	45	562	154				242	

Butterfly Valve, fully lugged version

4219 ZF

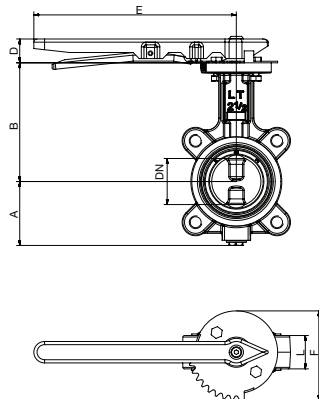

Materials

- Housing: GGG, GJS-400-15/JS1030, according to EN1563
- Disc: stainless steel 1.4408
- Spindle: stainless steel ASTM-A276 / Type 316
- Lever DN50-150: steel, ST14.03
- Lever DN200-300: steel, S235 DIN2458/1626
- Housing sealing: EPDM according to ISO 1691
- O-Ring: EPDM according to ISO 1691
- Flange: according to EN1092-2

Technical data

- Max. operating temp.: 110°C
- Min. operating temp.: -20°C

Order number	DN	PN10	PN16	PN25	A	B	L	D	E	F		Torque
1 4219 11	50	+	+	+	68	125	43	30	255	112	3.8	20
1 4219 12	65	+	+	+	80	150	46	30	255	112	4	20
1 4219 13	80	+	+	+	87	157	46	30	255	112	4.7	25
1 4219 14	100	+	+	+	102	182	52	30	255	112	6.3	50
1 4219 15	125	+	+	+	120	201	56	30	255	112	8.3	50
1 4219 16	150	+	+	+	132	214	56	30	255	112	10.1	90
1 4219 17	200	-	+	+	167	245	60	95	365	88	16.6	150
1 4219 58	250		+	+	207	283	68	133	519	130	24.5	250
1 4219 59	300		+	+	222	308	78	133	519	130	37.6	350
4 4219 30	350		+	+	277	388	92				49	
4 4219 31	400		+	+	308	416	102				90	
4 4219 32	450		+	+	342	455	114				110	
4 4219 33	500		+	+	374	490	127				150	
4 4219 34	600		+	+	459	562	154				242	



Gate Valve with non-rising spindle

4113



Material

- Body: DZR (CW 602N)
- Upper part: DZR (CW 602N)
- Handwheel: sheet steel, coated
- Sealing: EPDM

Technical data

- Max. operating pressure: 20 bar
- Max. operating temperature: 120°C
- Connection thread: ISO 7-1 Rp

Order number PN20	Order number PN20	DN	Rp	SW1	SW2	SW3	D	H	L
1 4113 11	1 4113 41	15	1/2	27	21	15	50	85	49.4
1 4113 12	1 4113 42	20	3/4	32	21	15	50	89.5	52.4
1 4113 13	1 4113 43	25	1	39	26	15	60	105.9	61
1 4113 14	1 4113 44	32	1 1/4	49	37	15	60	126	69.6
1 4113 15	1 4113 45	40	1 1/2	55	41	21	80	143.4	74
1 4113 16	1 4113 46	50	2	68	41	25	105	176.5	89

Gate Valve flanged version

4113

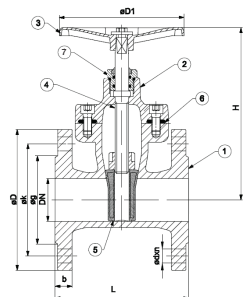

Order number PN16	Order number PN25	DN	PN	L	H	Icon
4 4113 21	5 4113 21	65	16	170	230	15
4 4113 22	5 4113 22	80	16	180	245	17
4 4113 23	5 4113 23	100	16	190	265	23
4 4113 24	5 4113 24	125	16	200	355	37
4 4113 25	5 4113 25	150	16	210	400	45
4 4113 26	5 4113 26	200	16	230	490	80
4 4113 27	5 4113 27	250	16	250	615	123
4 4113 28	5 4113 28	300	16	270	70	166
4 4113 29	5 4113 29	350	16	290	835	225
4 4113 30	5 4113 30	400	16	310	910	290
4 4113 31	5 4113 31	450	16	330	1000	400
4 4113 32	5 4113 32	500	16	350	1135	460
4 4113 33	5 4113 33	600	16	390	1300	680

Materials

- Body (1): GG25
- Bonnet (2): GG25
- Handwheel (3): GG25
- Stem (4): Stainless steel
- Wedge (5): GGG40 rubber plated
- Gasket (6): EPDM
- Gland (7): Brass CW617

Specification

- Temperature range: -10°C to +110°C
- Flange dim. according to EN1092-2
- Design standard EN1171

Backflow Preventer

2622

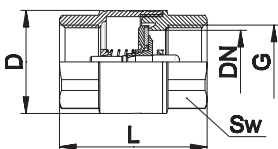

Order number	PN	DN	G	L	D	SW	Kvs	Icon
1 2622 41	25	15	1/2	49	31	25	10.5	0.132
1 2622 42	25	20	3/4	53	37	31	18	0.187
1 2622 43	25	25	1	58	46	39	29	0.270
1 2622 44	25	32	1 1/4	65	56	48	47.5	0.455
1 2622 45	25	40	1 1/2	69	68	55	75	0.670
1 2622 46	25	50	2	77	85	68	117	1.075

Materials

- Body: forged brass (CW617N) acc. EN 12420
- Seat: brass (CW614N) acc. EN 12164
- Holder: brass (CW614N) acc. EN 12164
- Spindle: brass (CW614N) acc. EN 12164
- Sealing: EPDM
- Spring: stainless steel (AISI 302) 1.4310
- Connections: female thread acc. ISO228

Technical data

- Operating pressure: depending on dimension, see table above
- Operating temperature range: -10°C to 110°C (water 0.5°C - 95°C, no steam)
- Medium: water, compressed air ... (non-aggressive mediums)

Swing Check Valve

2622

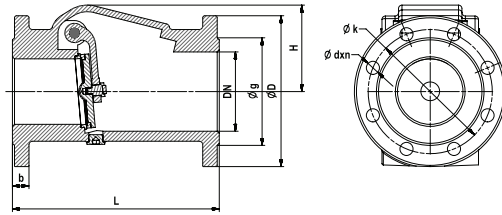

Specification

- Temperature range: -10°C ... +110°C
- Pressure rate: PN16
- Flange Dimensions according to EN1092-2
- Design standard EN 12334
- Coating painted blue RAL5000
- For hot and cold water systems for fluids excluding acid

Order number PN16	Order number PN25	DN	L	H	D	k	g	b	d	n	
4 2622 20	5 2622 20	50	180	70	165	125	99	20	19	4	7.5
4 2622 21	5 2622 21	65	240	87	185	145	118	20	19	4	10.5
4 2622 22	5 2622 22	80	260	104	200	160	132	22	19	8	14
4 2622 23	5 2622 23	100	300	125	220	180	156	24	19	8	20
4 2622 24	5 2622 24	125	350	157	250	210	184	26	19	8	30
4 2622 25	5 2622 25	150	400	186	285	140	211	26	23	8	43
4 2622 26	5 2622 26	200	500	240	340	295	266	20	23	12	70
4 2622 27	5 2622 27	250	600	295	405	355	319	22	28	12	120
4 2622 28	5 2622 28	300	700	372	460	410	370	25	28	12	164

Wafer Check Valve

2622



Order number PN16	Order number PN25	DN	Dim.	Kv Value
4 2622 31	5 2622 31	65	2 1/2	69
4 2622 32	5 2622 32	80	3	123
4 2622 33	5 2622 33	100	4	234
4 2622 34	5 2622 34	125	5	352
4 2622 35	5 2622 35	150	6	599
4 2622 36	5 2622 36	200	8	1188
4 2622 37	5 2622 37	250	10	2494
4 2622 38	5 2622 38	300	12	4044
4 2622 39	5 2622 39	350	14	5051
4 2622 40	5 2622 40	400	16	5500
4 2622 41	5 2622 41	450	18	6715
4 2622 42	5 2622 42	500	20	9430
4 2622 43	5 2622 43	600	24	15700

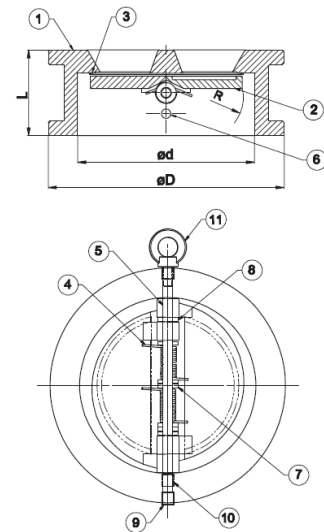

Materials

- Body (1): GG25
- Disc (2): GGG40
- Seat (3): EPDM
- Spring (4): Stainless steel
- Hinge pin (5): Stainless steel
- Stop pin (6): Stainless steel
- Disc Bearings (7): PTFE
- Body bearings (8): PTFE
- Plug (9): Steel
- Pin stabilizer (10): Rubber
- Eye bolt (11): Steel

Specification

- Temperature range: -10°C ... +110°C
- Pressure rate: PN16
- Flange Dimensions according to EN1092-2
- Design standard EN 12334
- Coating epoxy coated, blue RAL5000



Strainer, Mesh Width 0.5 mm

2662

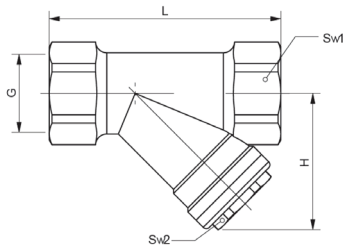

Order number	DN	PN	G	L	H	SW1	SW2	Kvs	Max. operating temp.
1 2662 01	15	25	1/2	68	37	25	22	2.55	110 °C
1 2662 02	20	25	3/4	90	46	32	24	5.60	110 °C
1 2662 03	25	25	1	90	54	41	25	8.20	110 °C

Material

- Body: CW617N
- Mesh: expanded metal, rhombic mesh, Stainless steel 1.4301, Mesh size 0,5 mm
- Sealings EPDM according KTW, WRAS and DVGW W270

Strainer, Mesh Width 0.75 mm

4111

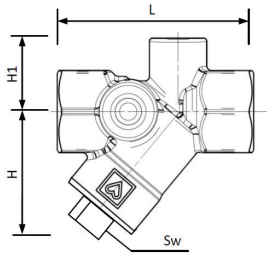

Order number	DN	G	L	H	H1	SW	Kvs	Max. operating temp.
1 4111 11	15	1/2	65	42.5	24	13	3.1	110 °C
1 4111 12	20	3/4	75	50	23	24	6.9	110 °C
1 4111 13	25	1	90	57.3	32	27	12	110 °C
1 4111 14	32	1 1/4	110	70	39	32	21.5	110 °C
1 4111 15	40	1 1/2	120	79	40	32	30.0	110 °C
1 4111 16	50	2	150	103	45	32	42.0	110 °C
1 4111 17	65	2 1/2	180	118	53	32	64.3	110 °C
1 4111 18	80	3	220	137	61	32	148.6	110 °C

Material

- Body: DZR
- Mesh: expanded metal, rhombic mesh, Stainless steel 1.4301, Mesh size 0,75mm
- Sealings: EPDM according KTW, WRAS and DVGW W270

Strainer with Drain Valve

4111

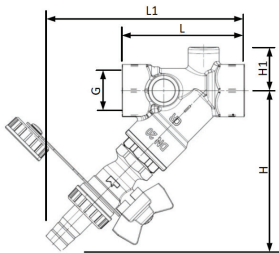
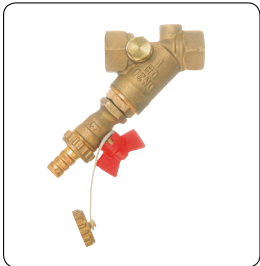

Order number	DN	PN	G	L	L1	H	H1	Kvs	Max. operating temp.
1 4111 41	15	10	1/2	65	112	102	24	3.1	110 °C
1 4111 42	20	10	3/4	75	122	111	26	7.1	110 °C

Material

- Body: DZR (CC752S)
- Mesh: expanded metal, rhombic mesh, Stainless steel 1.4301, Mesh size 0,75mm
- Sealings: EPDM according KTW, WRAS and DVGW W270

Cast Iron Strainer

4111



Order number PN16	Order number PN25	DN	Dim.	Kvs
4 4111 80	5 4111 80	50	2	51
4 4111 81	5 4111 81	65	2 1/2	70
4 4111 82	5 4111 82	80	3	114
4 4111 83	5 4111 83	100	4	197
4 4111 84	5 4111 84	125	5	271
4 4111 85	5 4111 85	150	6	349
4 4111 86	5 4111 86	200	8	449
4 4111 87	5 4111 87	250	10	994
4 4111 88	5 4111 88	300	12	1566
4 4111 89	5 4111 89	350	14	2461
4 4111 90	5 4111 90	400	16	3186

Materials

- Body: GG25
- Bonnet: GG25
- Filter: AISI 304
- Reinforcing frame: Stainless steel
- Gasket: Klingerit
- Plug gasket: Copper
- Plug: Steel St37

Specification

- Temperature range: -10°C to +110°C
- Pressure rate: PN16
- Flange Dimensions according to EN1092-2
- Coating painted blue RAL5000

Ball valves

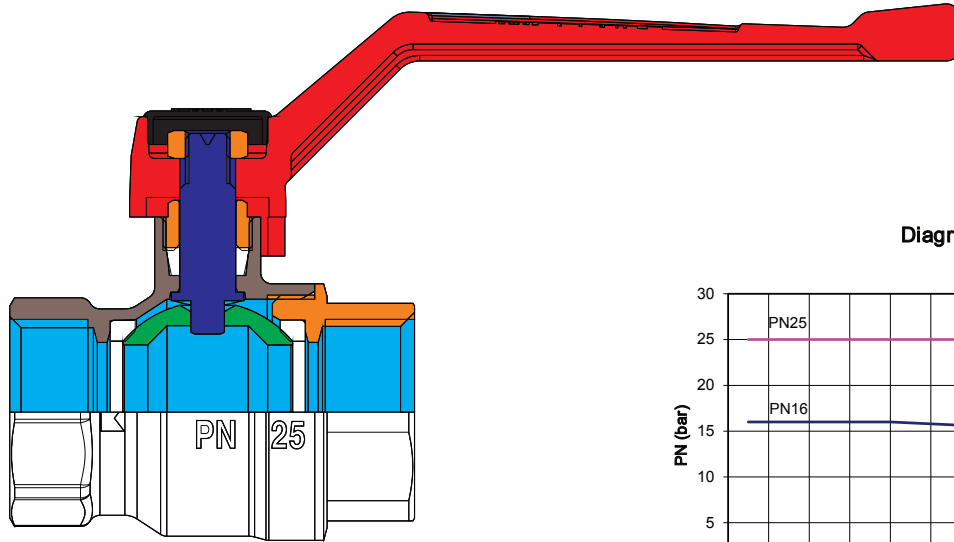

Diagram PN-T

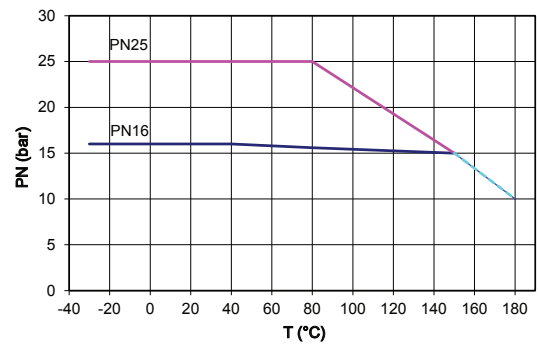
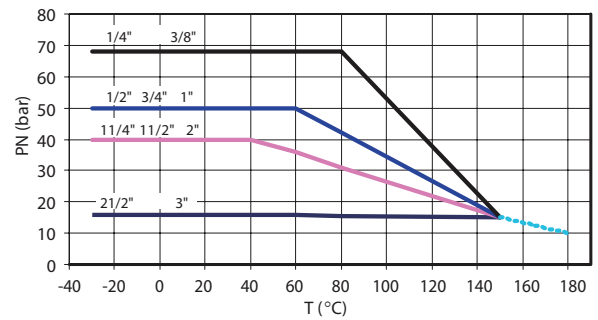
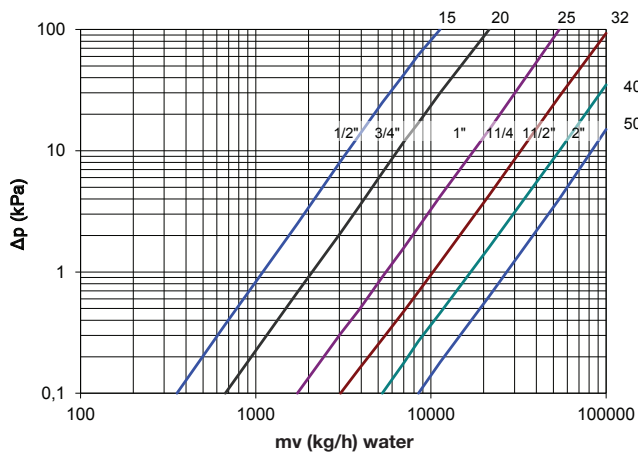
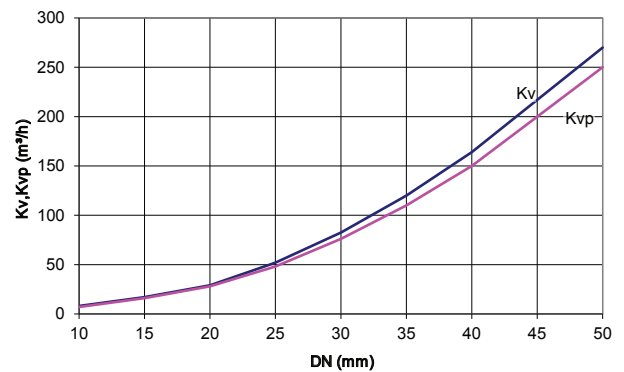

Diagram PN-T (pressure-temperature)
Diagram PN-T (pressure-temperature)



DN	15	20	25	32	40	50
Kv	17	34	55	102	165	270
Kvp	15,8	31,5	51	95	153	250

- Kv:** Outflow characteristic (m³ / h) - is the flow of water at temperature 15.5°C, a pressure drop of 1 bar (100 kPa) and a fully open valve.
- Kvp:** Outflow characteristic (m³ / h) - is the flow of air with density of 1,16 kg/m³ at temperature 15.5°C, a pressure drop of 1 mbar (0,1 kPa) and a fully open valve.





Ball Valve WRAS approved

2190 0X

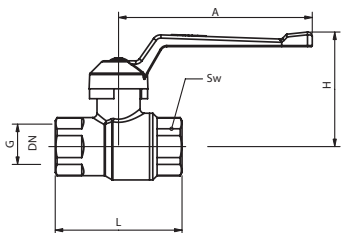

2190 2X

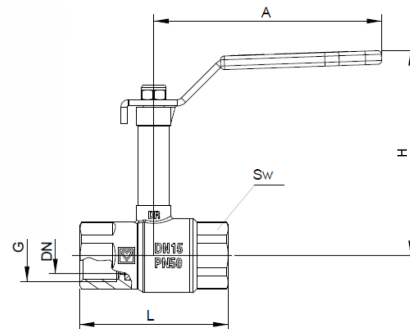
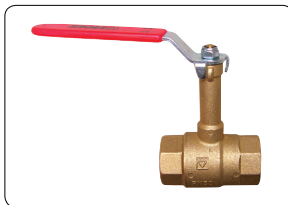

Order number	DN	PN	G	L	H	A	Sw	Max. operating temp.
1 2190 01	15	50	1/2"	59	53	90	25	120 °C
1 2190 02	20	50	3/4"	65	56	90	32	120 °C
1 2190 03	25	50	1"	80.5	77	135	41	120 °C
1 2190 04	32	40	1 1/4"	91	81	135	48	120 °C
1 2190 05	40	40	1 1/2"	104	95	180	55	120 °C
1 2190 06	50	40	2"	125.5	101	180	70	120 °C
1 2190 07	65	16	2 1/2"	146	124	210	88	120 °C
1 2190 08	80	16	3"	179	134	210	105	120 °C
1 2190 21	15	25	1/2"	59	90	90	25	120 °C
1 2190 22	20	25	3/4"	65	93	90	32	120 °C
1 2190 23	25	25	1"	80.5	107	135	41	120 °C
1 2190 24	32	25	1 1/4"	91	111	135	48	120 °C
1 2190 25	40	25	1 1/2"	100	136	180	55	120 °C
1 2190 26	50	25	2"	118	144	180	68	120 °C

Materials

- Body: 1 2190 01 - 06 and 1 2190 21 - 26 forged DZR brass, CW602N
1 2190 07 - 08 DZR brass CC752S
- Ball: forged DZR brass, full bore, surface chrome plated
- Spindle: brass
- Lever: 1 2190 01 - 08, Aluminium red painted
1 2190 21 - 26, Steel zinc coated, red plastic covered
- Sealing: Ball: PTFE, Spindle: EPDM

Full Port Ball Valve

I 0491



Specifications

- Pressure Rating PN 30
- Temperature Rating max. 100°C water (no steam), (depending on pressure)
- Forged Brass Nickel Plated Body
- Threaded Ends according to ISO 228
- Full Port Opening
- Blow Out Proof Stem

Materials

- Valve Body: CuZn40Pb2 - DIN EN 12165
- Seat Ring: PTFE
- Ball CuZn40Pb2 - DIN EN 12165
- Retainer-body end: CuZn40Pb2 - DIN EN 12165
- Stem: CuZn40Pb2 - DIN EN 12165
- "O"Ring: NBR 70 Shore
- Handle: Aluminium, AlSi11Cu2(Fe)
- Handle: screw Steel, zinc plated

Order number	D	G	Handle
I 0491	15	1/2"	T-form
I 0491	20	3/4"	T-form
I 0491	25	1"	T-form
I 0491	32	1 1/4"	lever
I 0491	40	1 1/2"	lever
I 0491	50	2"	lever

Ball Valve PN 25, socket x socket, DZR

2206 with lever handle

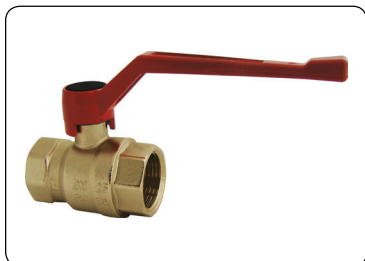

2206 with T-handle

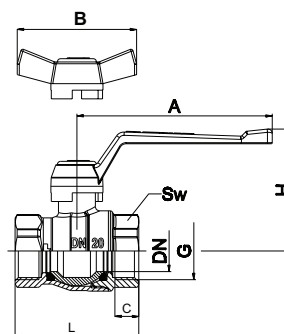

Order number	DN	PN	G	L	C	H	A	B	Sw
1 2206 01	15	25	G1/2"	51	10	53	90	-	25
1 2206 02	20	25	G3/4"	57	11	56	90	-	31
1 2206 03	25	25	G1"	73	14	73	135	-	39
1 2206 04	32	25	G1-1/4"	84	16	79	135	-	48
1 2206 05	40	25	G1-1/2"	95	17	93	180	-	55
1 2206 06	50	25	G2"	112	19	99	180	-	70
1 2206 11	15	25	G1/2"	51	10	42	-	55	25
1 2206 12	20	25	G3/4"	57	11	46	-	55	31
1 2206 13	25	25	G1"	73	14	57	-	75	39
1 2206 14	32	25	G1-1/4"	84	16	63	-	75	48

T= -30°C... +150°C

Ball Valve PN 25, socket x socket, DZR

2206 with lever handle



2206 with T-handle

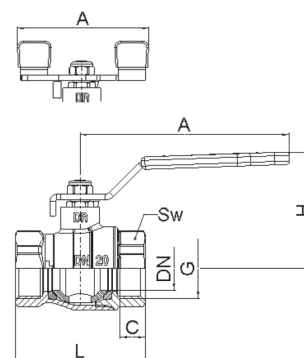

Order number	DN	PN	G	L	C	H	A	Sw
1 2206 21	15	25	G1/2"	51	10	48	90	25
1 2206 22	20	25	G3/4"	57	11	51	90	31
1 2206 23	25	25	G1"	73	14	63	135	39
1 2206 24	32	25	G1-1/4"	84	16	69	135	48
1 2206 25	40	25	G1-1/2"	95	17	85	180	55
1 2206 26	50	25	G2"	112	19	91	180	70
1 2206 31	15	25	G1/2"	51	10	45	60	25
1 2206 32	20	25	G3/4"	57	11	48	60	31
1 2206 33	25	25	G1"	73	14	65	85	39
1 2206 34	32	25	G1-1/4"	84	16	71	85	48

T= -30°C... +150°C



Ball Valve with T-handle, socket x socket

2206 red plastic



2206 blue plastic

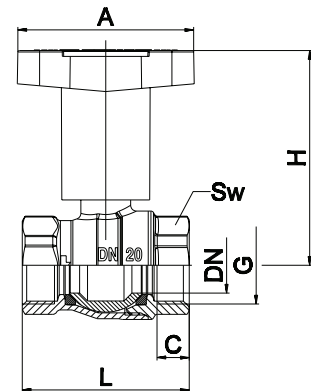

Order number	DN	PN	G	L	C	H	A	Sw
1 2206 41	15	25	G1/2"	51	10	70	60	25
1 2206 42	20	25	G3/4"	57	11	73	60	31
1 2206 43	25	25	G1"	73	14	82	85	39
1 2206 44	32	25	G1-1/4"	84	16	88	85	48
1 2206 45	40	25	G1-1/2"	95	17	120	120	55
1 2206 46	50	25	G2"	112	19	126	120	70
1 2206 51	15	25	G1/2"	51	10	70	60	25
1 2206 52	20	25	G3/4"	57	11	73	60	31
1 2206 53	25	25	G1"	73	14	82	85	39
1 2206 54	32	25	G1-1/4"	84	16	88	85	48
1 2206 55	40	25	G1-1/2"	95	17	120	120	55
1 2206 56	50	25	G2"	112	19	126	120	70

T= -30°C... +150°C

Material

- Body: forged brass acc. EN 12420
- Nut: forged brass acc. EN 12420
- Ball: forged brass, hollow bore, chrome plated
- Spindle: mached brass
- Handle: plastic, red
- Connections: connection thread acc. to ISO 228
- Sealing elements: PTFE- polytetrafluoretylen (ball), PTFE- polytetrafluoretylen (spindle)

Ball Valve with T-handle and thermometer, socket x socket

2206 red plastic



2206 blue plastic

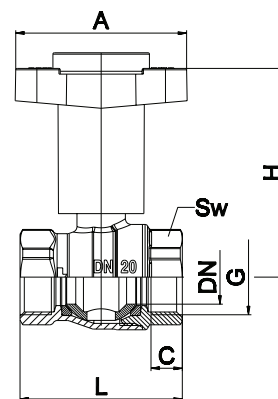

Order number	DN	PN	G	L	C	H	A	Sw
1 2206 61	15	25	G1/2"	51	10	70	60	25
1 2206 62	20	25	G3/4"	57	11	73	60	31
1 2206 63	25	25	G1"	73	14	82	85	39
1 2206 64	32	25	G1-1/4"	84	16	88	85	48
1 2206 65	40	25	G1-1/2"	95	17	120	120	55
1 2206 66	50	25	G2"	112	19	126	120	70
1 2206 71	15	25	G1/2"	51	10	70	60	25
1 2206 72	20	25	G3/4"	57	11	73	60	31
1 2206 73	25	25	G1"	73	14	82	85	39
1 2206 74	32	25	G1-1/4"	84	16	88	85	48
1 2206 75	40	25	G1-1/2"	95	17	120	120	55
1 2206 76	50	25	G2"	112	19	126	120	70

T= -30°C... +150°C

Material

- Body: forged brass acc. EN 12420
- Nut: forged brass acc. EN 12420
- Ball: forged brass, hollow bore, chrome plated
- Spindle: mached brass
- Handle: plastic, red
- Connections: connection thread acc. to ISO 228
- Sealing elements: PTFE- polytetrafluoretylen (ball), PTFE- polytetrafluoretylen (spindle)

Ball Valve

2100 with lever handle



2100 with T-handle

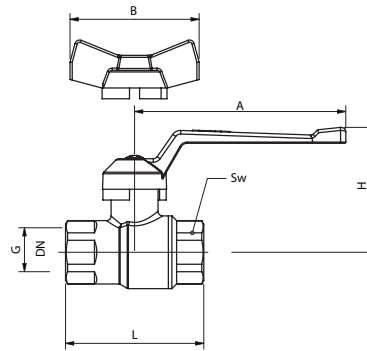

Order number	PN	DN	G	L	A	B	H	Sw		
1 2100 09	63	8	1/4"	43	60	-	44	17	0.115	25
1 2100 00	63	10	3/8"	45	60	-	46	21	0.140	25
1 2100 01	50	15	1/2"	59	90	-	53	25	0.235	25
1 2100 02	50	20	3/4"	65	90	-	57	32	0.355	25
1 2100 03	50	25	1"	80	135	-	71	41	0.625	20
1 2100 04	40	32	1-1/4"	91	135	-	75	48	0.965	16
1 2100 05	40	40	1-1/2"	104	180	-	93	55	1.660	8
1 2100 06	40	50	2"	125	180	-	101	70	2.720	4
1 2100 07	16	65	2-1/2"	146	265	-	124	85	4.200	2
1 2100 08	16	80	3"	179	265	-	134	105	6.200	2
1 2100 19	63	8	1/4"	43	-	40	44	17	0.115	25
1 2100 10	63	10	3/8"	45	-	40	46	21	0.140	25
1 2100 11	50	15	1/2"	59	-	55	53	25	0.235	25
1 2100 12	50	20	3/4"	65	-	55	57	32	0.355	25
1 2100 13	50	25	1"	80	-	75	71	41	0.625	20
1 2100 14	40	32	1-1/4"	91	-	75	75	48	0.965	16

T= -30°C... +150°C

Materials

- Body: 1 2100 01-06 forged brass acc. EN 12420, CW617, nickel-plated
1 2100 07-08 DZR Brass CC752S, nickel-plated
- Ball: pressed brass, full bore, machined to a microsmooth, finish, chrome plated
- Spindle: brass
- Handle: Aluminium alloy, plastic red dipped
- Sealing elements: PTFE-Polytetrafluorethylen (ball and spindle)
- Conections: female thread acc. ISO228



Multifunction Ball Valve with Thermometer

2414 with red T-handle



2414 with blue T-handle

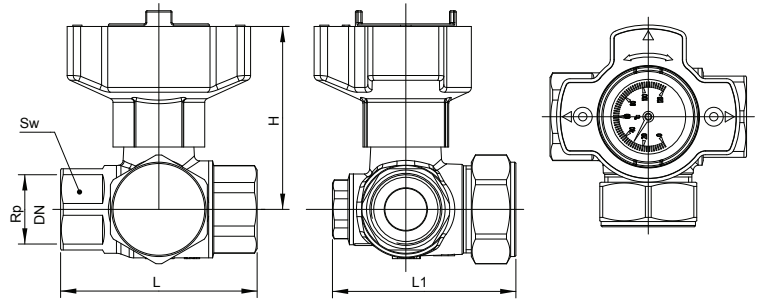

Order number	PN	DN	Rp	Sw	L	L1	H	blue T-h.	red T-h.	Weight	Volume
1 2414 02	25	20	3/4"	32	75	65	70		x	0.630	20
1 2415 02	25	20	3/4"	32	75	65	70	x		0.630	20
1 2414 03	25	25	1"	41	96	98	75		x	1.200	10
1 2415 03	25	25	1"	41	96	98	75	x		1.200	10
1 2414 04	25	32	1-1/4"	50	109	113	81		x	1.400	10
1 2415 04	25	32	1-1/4"	50	109	113	81	x		1.400	10

T min.= -10°C (short time -30°C), water 0.5°C
 T max.= 130°C (short time 150°C), water 110°C

Ball Valve with hose union WRAS approved

2512

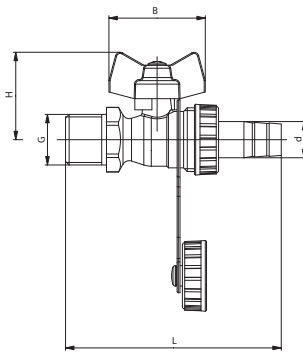

Materials

- Body: CW617N
- Ball: CW617N, full bore, Surface chrome plated
- Spindle: brass CW614N
- Locking bolt: Aluminium red painted
- Sealings: PTFE (ball), PTFE (spindle)

Order number	PN	DN	G	L	L1	d	H	H1	B	Sw	Weight	Volume
1 2512 01	25	10	1/2"	83	-	15	37	-	40	24	0.170	50
1 2512 01	25	15	3/4"	98	-	19	40	-	40	30	0.290	50

T = -10 °C...+110 °C

Air Separator combined with automatic air vent

I 0124

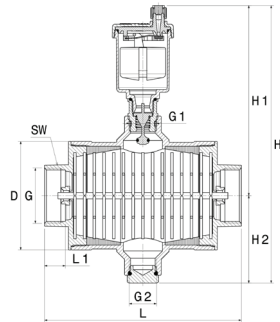

Order number	G	D	L	L1	G1	G2	H	H1	SW	
I 0124 02	3/4"	83	170	18	1/2"	1/2"	214	67	38	1
I 0124 03	1"	83	151	16,5	1/2"	1/2"	214	67	38	1
I 0124 02	1 1/4"	83	151	16	1/2"	1/2"	214	67	47	1
I 0124 02	1 1/2"	83	154	17,5	1/2"	1/2"	214	67	54	1
I 0124 02	2"	83	155	17	1/2"	1/2"	214	67	66	1

Air Release Valve

2630

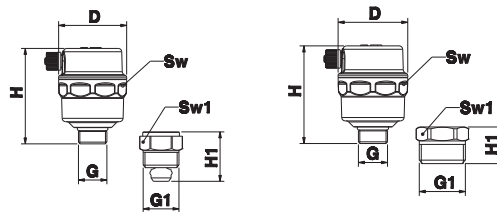

Order number	PN	D	G	G1	H	H _{min}	H _{max}	H1	Sw	Sw1		Colour of the nut	Backflow preventer
1 2630 00	10	40	3/8	3/8	56	30	38	30	38	22	0.224	black	
1 2630 01	10	40	3/8	1/2	56	30	38	26	38	22	0.216	black	Yes
1 2630 02	10	40	3/8	/	56	/	38	/	38	/	0.182	black	
1 2630 03	10	40	3/8	3/4	56	30	38	21	38	27	0.226	black	
1 2630 10	10	40	3/8	/	56	/	38	/	38	/	0.188	red	
1 2630 11	10	40	3/8	3/8	56	30	38	30	38	22	0.226	red	Yes

Stop Valve

2621



Brass body, with O-ring, PN 10, G 1/2.
Temperature range is from 0 °C to +100 °C.
Rp 1/2 – Rp 3/8.

Order number	PN	Dim.
1 2621 01	10	15



Ball Valve for pump with check valve

2268

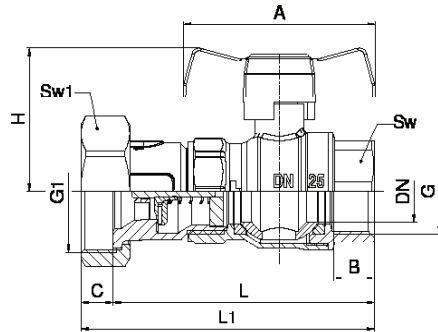

Order number	PN	DN	G	G1	L	L1	A	B	C	H	Sw	Sw1	
1 2268 03	16	25	1"	1-1/2"	102	114,5	75	16	12,5	56	39	52	0,76

T = -10 °C...+110 °C

Ball Valve for pump

2269

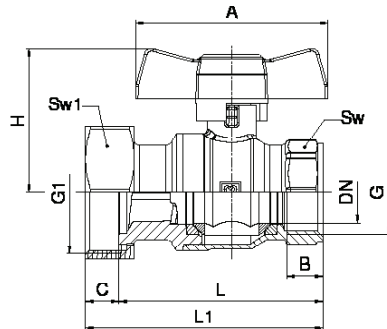

Order number	PN	DN	G	G1	L	L1	A	B	C	H	Sw	Sw1	
1 2269 03	16	25	1"	1-1/2"	79,5	92,5	75	14	13	56	39	52	0,59

T = -10 °C...+110 °C

Check Valve and Pump Connection

2634



Brass body, with O-ring, PN 10, G 1/2.
Temperature range is from 0 °C to +100 °C.
Rp 1/2 – Rp 3/8.

Order number	PN	Dim.
1 2634 03	25	25

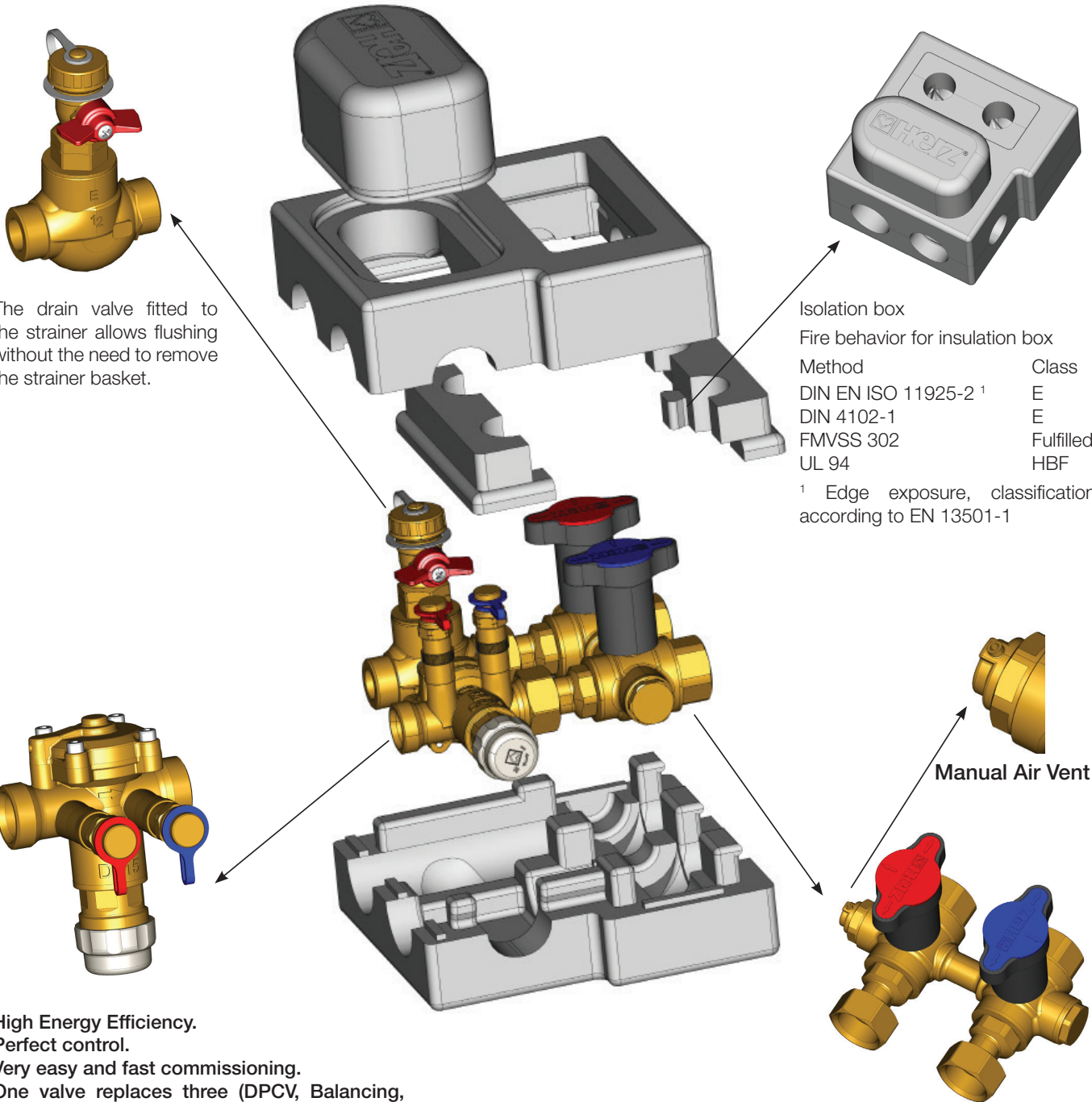

The drain valve fitted to the strainer allows flushing without the need to remove the strainer basket.

Isolation box
 Fire behavior for insulation box

Method	Class
DIN EN ISO 11925-2 ¹	E
DIN 4102-1	E
FMVSS 302	Fulfilled
UL 94	HBF

¹ Edge exposure, classification according to EN 13501-1

High Energy Efficiency.
Perfect control.
 Very easy and fast commissioning.
 One valve replaces three (DPCV, Balancing, Control) Optimization of pump head No required calculation and verification of the valve authority. Lower operational or maintenance costs due to less complaints/ longer life-span of actuator.

HERZ-Multifunction Ball Valve Block with red and blue "T" Handle
 Three-Port-Ball Valves.
 T port of ball with full bore allows the draining or filling of full systems or part of the systems.



HerzCON

Pressure Independent Connect-4 with insulation

HerzCON

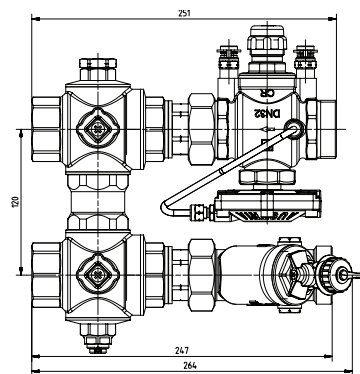
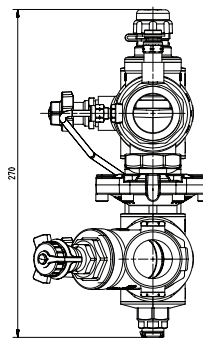
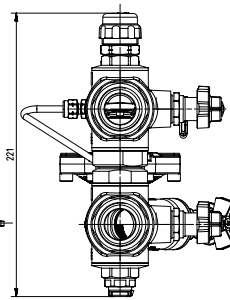
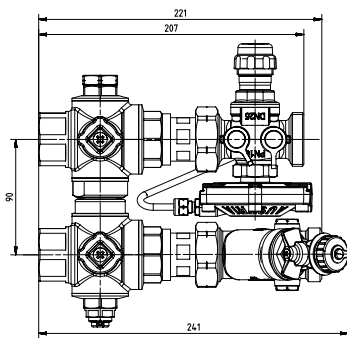
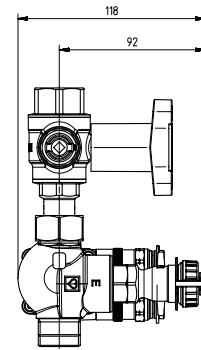
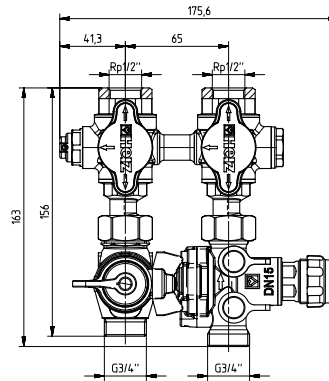
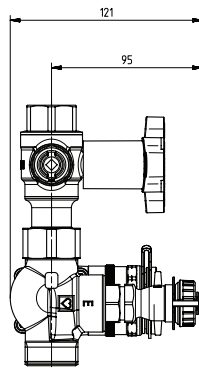
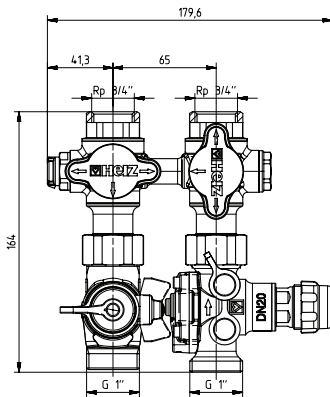
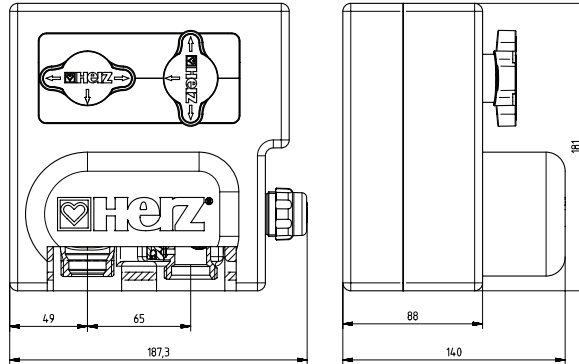
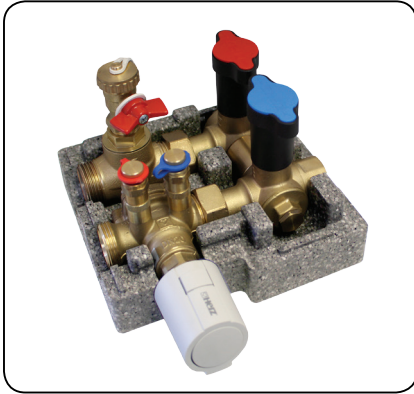

Order number	DN	kvs value of PIBCV	Insulation box
1 4600 51	15	0.94	yes
1 4600 52	20	1.71	yes
1 4600 58	25	1.90	yes
1 4600 54	32	2.50	-

Technical data

- Max. operating pressure: 25 bar
- Min. operating temperature: - 20 °C
- Max. operating temperature: 130 °C
- Lift: 4 mm

Materials

- Body: DZR
- Membranes and O-rings: EPDM

Connect-4

Pressure Independent Connect-4 with insulation PN 25

4600



HERZ Connect-4 has been designed to give a simple connection to fan-coils, or other terminal units, and utilises the HERZ 4006 SMART or HERZ 4006 Pressure Independent Balancing Control Valve with HERZ 2206 ball valves with T-handle and a HERZ 4111 strainer. On/off or modulating 0 – 10 V DC actuators can be fitted and integrated to a BMS if required.

The unit allows pressure independent control ensuring full stroke regardless of pressure fluctuations, while guaranteeing a constant flow rate to the terminal unit maximising energy efficiency for the system. The Connect-4 unit also permits flushing and isolating operations to be undertaken. The Connect-4 is fitted with test points.

The Connect-4 is fitted in a insulation box. This means there is no product differentiation between heating and chilled, one unit does both applications. The drain cock fitted to the strainer allows flushing without the need to remove the strainer basket and also allows the strainer basket to be cleaned in-situ.

Order number	Dim.	Kvs
1 4600 11	15	0.94
1 4600 12	20	1.71
1 4600 13	25	1.90
1 4600 14	32	2.50
1 4600 15	40	5.00
1 4600 16	50	5.00
1 4600 17	20	0.90

Fan Coil Connection Hose, insulated

B200



Order number	Diameter
H B200 15	DN 15
H B200 20	DN 20
H B200 25	DN 25
H B200 32	DN 32
H B200 40	DN 40
H B200 50	DN 50

Technical data

- Hose Type: Standard braided metal hose acc. to DIN EN ISO 10380
- Hose Material: Stainless Steel AISI 316L, AISI 304, 321 also available upon request
- Temperature Range: Min. -270 °C up to max. 600 °C
- Fittings Materials: Carbon Steel St.37.2/Stainless Steel
- Insulation : Rubber based EPDM Insulation

Metal Expansion Joint

M220



Order number	Diameter
F M220 01	DN 65
F M220 02	DN 80
F M220 03	DN 100
F M220 04	DN 125
F M220 05	DN 150
F M220 06	DN 200
F M220 07	DN 250
F M220 08	DN 300



Rubber Expansion Joints

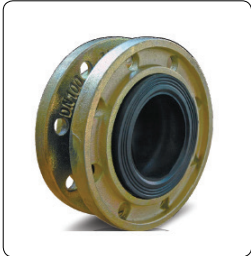

Order number	Diameter
F R220 01	DN 65
F R220 02	DN 80
F R220 03	DN 100
F R220 04	DN 125
F R220 05	DN 150
F R220 06	DN 200
F R220 07	DN 250
F R220 08	DN 300

Threaded Connection Elements with cone

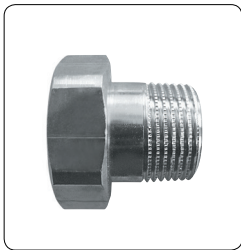

Order number	Shoulder throw	Dim.
1 6209 03	5/4	1
1 6209 03	1 3/4	1 1/4
1 6210 00	5/8	3/8
1 6210 21	3/4	1/2
1 6210 26	3/4	1/2 x 26
1 6210 11	3/4	1/2 x 35
1 6210 02	1	3/4

Iron pipe connection with cone, nut and connection element.

Threaded Connection Elements with cone flat seal iron pipe connection

6220



Order number	Shoulder throw	Rp.
1 6220 00	G 5/8	3/8
1 6220 20	G 1/2	3/8
1 6220 21	G 3/4	1/2
1 6220 12	G 1	3/4
1 6220 64	G 1 1/2	1 1/4
1 6220 74	G 2	1 1/4
1 6220 75	G 2 1/4	1 1/2
1 6220 76	G 2 3/4	2

Iron pipe connection with fl at seal with nut and seal, Rc for 4037, 7762, 7763, 7760.

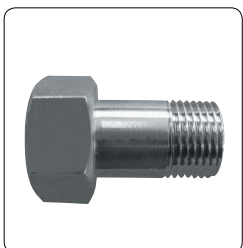

Order number	Shoulder throw	Rp.
1 6220 11	G 3/4	1/2 x 38 mm
1 6220 22	G 1	3/4 x 44mm
1 6220 63	G 1 1/4	1
1 6220 65	G 1 3/4	1 1/2
1 6220 66	G 2 3/8	2

Iron pipe connection with fl at seal with nut, connection element and seal. 4004, 4315, 4325, 4415, 4417, 4207, 7761, 7217, 4216, 7766.

Plastic Pipe Connections for PE-X, PE-RT, PB and Aluminium Composite Pipes

6098

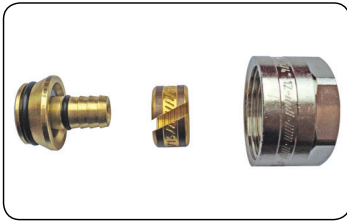

Order number	Dim.
1 6098 18	10 x 1.3
1 6098 02	14 x 2
1 6098 16	15 x 2.5
1 6098 03	16 x 2
1 6098 13	16 x 2.25
1 6098 04	17 x 2
1 6098 05	17 x 2.5
1 6098 07	18 x 2
1 6098 06	18 x 2.5
1 6098 17	18 x 3
1 6098 08	20 x 2
1 6098 20	20 x 2.25
1 6098 10	20 x 3.5
1 6098 11	20 x 2.5
1 6098 09	20 x 2.8
1 6098 19	20 x 3.4

Plastic Pipe Connections 3/4 For PE-X, PB and aluminium composite pipes, consisting of spigot, olive and union nut G 3/4. With cone.

6066

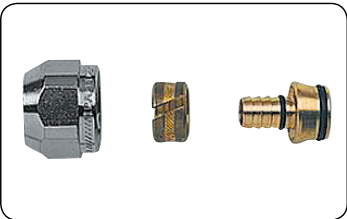

Order number	Dim.
1 6066 02	14 x 2
1 6066 03	16 x 2
1 6066 04	17 x 2

Plastic Pipe Connections M 22 x 1.5 For PE-X, PB and aluminium composite pipes, consisting of spigot, olive and union M 22 x 1.5.

6092



Order number	Dim.
1 6092 11	12 x 2
1 6092 12	14 x 2
1 6092 13	16 x 2

Plastic Pipe Connection G 1/2 with double O-Ring and insulating disc, consisting of spigot, and olive and union nut G 1/2 with cone.

6198



Order number	Dim.
1 6198 11	16 x 2
1 6198 12	20 x 2
1 6198 00	25 x 3.5
1 6198 01	26 x 3

Plastic Pipe Connections G 1. For PE-X, PB and aluminium composite pipes, consisting of spigot, olive and union nut G 1 with cone.



PERT Pipe



Order number	Diameter
U 1622 40	16 x 2
U 1624 80	16 x 2
U 1626 00	16 x 2
U 1722 40	17 x 2
U 1724 80	17 x 2
U 1726 00	17 x 2
U 1822 40	18 x 2
U 1824 80	18 x 2
U 2022 40	20 x 2
U 2024 80	20 x 2

HVAC

Water

Gas



02/ Water

Each drop counts

WATER

Diaphragm Pressure Reducer

2682

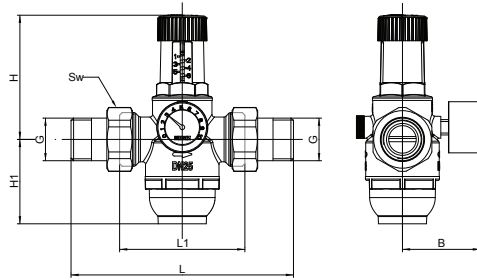

Order number	DN	PN	G	L	L1	B	H	H1	Sw		
1 2682 11	15	16	1/2"	147	84	67	98	66	30	0.745	6
1 2682 12	20	16	3/4"	155	84	67	98	66	37	0.901	6
1 2682 13	25	16	1"	185	98	67	98	66	46	1.185	6
1 2682 14	32	16	1 1/4"	204	120	77,5	156	100	52	2.276	4
1 2682 15	40	16	1 1/2"	224	122	77,5	156	100	60	2.720	4
1 2682 16	50	16	2"	252	136	77,5	156	100	75	3.487	4

Outlet pressure range = 0.5 ... 6 bar, T = 0.5°C... + 40°C

Drain valve with connection for hose

2503

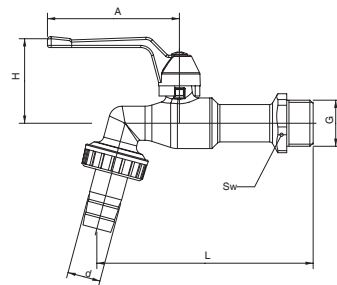
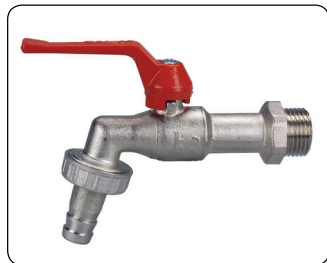

Order number	PN	DN	G	L	d	A	B	H	Sw		
1 2503 01	16	10	1/2"	98	15	60	-	38	25	0.205	25
1 2503 02	16	15	3/4"	103	19	60	-	41	30	0.260	25

T = 0 °C...+90 °C

Backflow preventer

4126

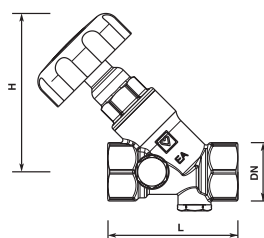

Order number	DN	L	H	Rp
2 4126 01	15	65	82	1/2
2 4126 02	20	75	92	3/4
2 4126 03	25	90	150	1
2 4126 04	32	110	118	1 1/4
2 4126 04	40	120	127	1 1/2
2 4126 05	50	150	155	2

Technical Data

- Max. pressure: 16 bar
- Max. pressure on the closed valve: 10 bar
- Operating pressure from the backflow preventer: according to DIN EN 13959
- Max. operating temperature: 80°C
- Max. temperature: 95°C not longer than 1 hour
- Valve getting closed right-turned



Backflow Preventer

2623

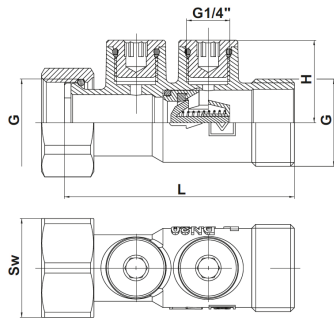

Order number	Dim.	DN	G	L	L1	H	Sw
1 2623 02	3/4	20	3/4	69.5	84	25	30
1 2623 03	1	25	1	74.5	84	27.5	36
1 2623 04	1 1/4	32	1 1/4	91	98	33	46

Technical Data

- Max. operating pressure: 16 bar
- Max. operating temperature: 95 °C
- Min. operating temperature: -10 °C, Water 0.5 °C
- Media: clear liquids

Compact Distributors for Sanitary Installation DN 20

8451

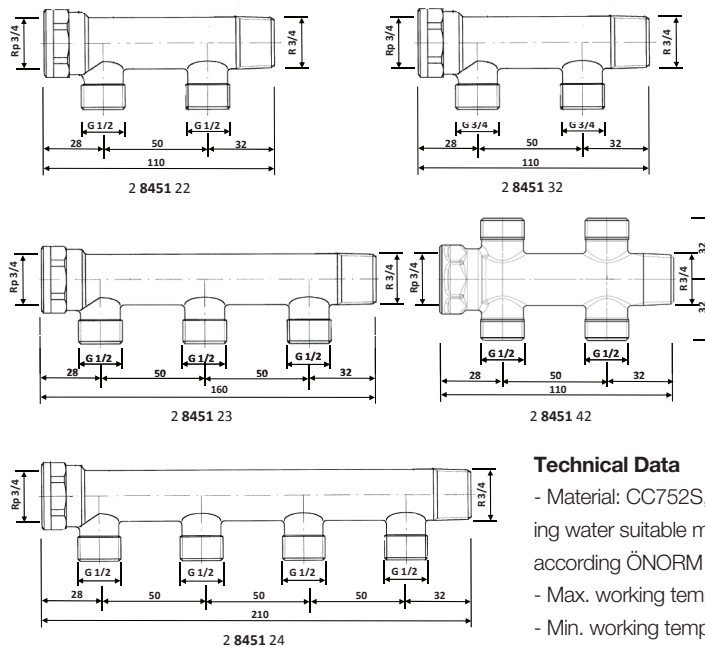

Order number	Dim.
2 8451 22	with 2 outlets
2 8451 23	with 3 outlets
2 8451 24	with 4 outlets
2 8451 32	with 2 outlets
2 8451 42	with 4 outlets

Technical Data

- Material: CC752S, (CuZn35Pb2Al-C), Hygienic drinking water suitable material for product group B and C, according ÖNORM B5014-3.
- Max. working temperature: 110°C
- Min. working temperature: 10°C
- Max. Pressure: 10 bar

Wall-Angles with female thread

T 3124



Order number	G	Rp
P 3124 14	1/2	1/2
P 3126 14	3/4	1/2
P 3126 15	3/4	3/4

Test Point

0284



Order number	Dim.
2 0284 20	1/4

Test Points with draining function Brass version, green cap, with swivel hose connection. Test point for flow computer.

WATER

Balancing Valves for hydronic balancing in drinking water installations

4017 M

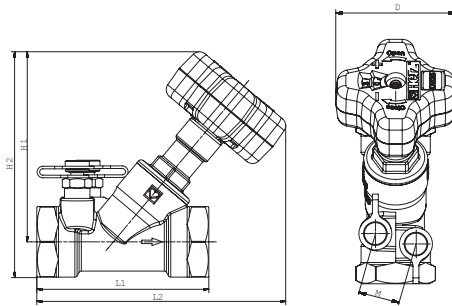

Technical data:

- Max. operating temperature 85 °C at 10 bar
- Max. operating pressure 20 bar at 20 °C
- Max. differential pressure at closed valve 10 bar

- body: DZR brass
- non-rising stem sealed with Double-O-Ring
- presetting through stroke limiting,
- handwheel with presetting digital display

Order number	DN	L1	L2	H1	H2	M	D	Kvs valve	Kvs Orifice
2 4017 00	15 LF	83	129	96	109	25	70	0.46	0.48
2 4017 09	15 MF	83	129	96	109	25	70	0.88	0.97
2 4017 01	15	83	129	96	109	25	70	2.00	1.95
2 4017 02	20	91	135	99	115	25	70	3.60	3.95
2 4017 03	25	110	146	109	130	25	70	6.50	7.90
2 4017 04	32	122	159	117	142	25	70	13.30	15.75
2 4017 05	40	135	178	136	163	25	70	18.50	21.50
2 4017 06	50	164	197	140	175	25	70	33.00	46.70

Ball Valves for flush mounting

2202

2202 with lever handle

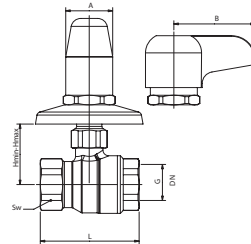

Materials

- Body: forged brass acc. to EN 12420, CW617N
- Ball: forged brass acc. to EN 12420, full bore, hard chrome plated, CW617N
- Spindle: turned brass acc. to EN 12164, CW614N
- Handle: Zamak 410 - chrome plated
- Connectors: Female thread acc. ISO 228
- Ball seals: PTFE
- Spindle seals: EPDM 70 ShA

Order number	PN	DN	G	L	A	B	Hmin	Hmax	Sw		
1 2202 01	16	15	1/2"	59	24	-	25	40	25	0.230	25
1 2202 02	16	20	3/4"	65	24	-	30	45	32	0.345	25
1 2202 11	16	15	1/2"	59	-	40	25	40	25	0.240	25
1 2202 12	16	20	3/4"	65	-	40	30	45	32	0.355	25

Angle Valves

1 2550 01



1 2552 01



1 2553 01



1 2554 01



HERZ angle valves for potable water have to be used as shut off elements. Field of application are water installations where we need to connect plumbing fittings, flow meter heaters. Angle valves are used wherever the medium flow has to be reliably closed. Angle valve should not be used as regulating element so it has to be fully opened or fully closed (the handle should not be in intermediate position). Angle ball valve 1 2553 01 and 1 2554 01 have integrated filter that allows water filtration.



Mixing Valves for drinking water

7766

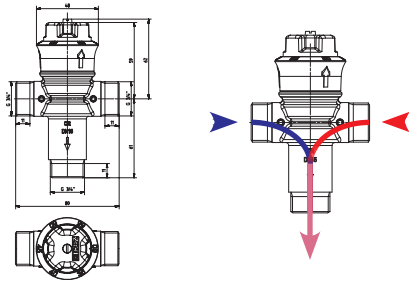

Order number	Connection thread	Mixing temperature set value	Mixed water temp. hysteresis	Max. static pressure	Max. dynamic pressure	Min. flow	Flow at 3 bar
2 7766 54	G 3/4	35-60 °C	±2 °C	10 bar	0.2-6 bar	4 l/min	42 l/min

Backflow Preventer

I 0307



Order number	Dim.
I 0307 01	1 1/2 x 1 1/2 - IG x IG
I 0307 02	1 1/2 x 1 1/2 - IG x AG
I 0307 03	1 1/2 x 1 1/2 - AG x AG
I 0307 04	1 1/2 x 1 1/2 - AG x IG
I 0307 05	2 x 2 - IG x IG
I 0307 06	2 x 2 - IG x AG
I 0307 07	2 x 2 - AG x AG
I 0307 08	2 x 2 - AG x IG
I 0307 09	1 1/2 x 2 - IG x IG
I 0307 10	1 1/2 x 2 - IG x AG
I 0307 11	1 1/2 x 2 - AG x AG
I 0307 12	1 1/2 x 2 - AG x IG
I 0307 13	2 x 1 1/2 - IG x IG
I 0307 14	2 x 1 1/2 - IG x AG
I 0307 15	2 x 1 1/2 - AG x AG
I 0307 16	2 x 1 1/2 - AG x IG

HERZ Backflow Preventer type BA according to DIN EN 1717, providing protection against non-drinking water up to hazard class 4. Threaded connections are mutually interchangeable. Nominal pressure PN 10, max. temperature 65°C, (short-term 80°C). Medium: water.

Pressure Relief Safety Valve

2611 -2613



2604 - 2689



Order number	PN	Dim.	Boiler output
1 2611 01	2.5	15	50 kW
1 2612 01	3	15	50 kW
1 2613 01	6	15	50 kW
1 2604 02	2.5	20	100 kW
1 2605 02	3	20	100 kW
1 2606 02	6	20	100 kW
1 2607 03	2.5	25	200 kW
1 2608 03	3	25	200 kW
1 2667 03	6	25	200 kW
1 2687 03	8	25	200 kW
1 2609 04	2.5	32	350 kW
1 2610 04	3	32	350 kW
1 2669 04	6	32	350 kW
1 2689 04	8	32	350 kW

2611 - 2613

Body made of forged brass, EPDM Diaphragm, cap seals and plastic. Temperature range is from 0°C to +110°C. For boiler output to 50 kW, DN 15. According to TÜV.

2604 - 2606

Body made of forged brass, EPDM Diaphragm, cap seals and plastic. Temperature range is from 0°C to +110°C. For boiler output to 100 kW, DN 15.

2607 - 2687

For boiler output to 200 kW, DN 25.

2609 - 2689

For boiler output to 350 kW, DN 32.

WATER

Tilting Check Valve

2622



Order number PN16	Order number PN25	Weight (Kg) PN25	DN
4 2622 50	5 2622 50	13	50
4 2622 51	5 2622 51	21	65
4 2622 52	5 2622 52	22	80
4 2622 53	5 2622 53	25	100
4 2622 54	5 2622 54	40	125
4 2622 55	5 2622 55	52	150
4 2622 56	5 2622 56	149	200
4 2622 57	5 2622 57	182	250
4 2622 58	5 2622 58	316	300
4 2622 59	5 2622 59	432	350
4 2622 60	5 2622 60	550	400
4 2622 61	5 2622 61	670	450
4 2622 62	5 2622 62	880	500
4 2622 63	5 2622 63	1102	600

Features:

- can be installed in any direction
- resistant to temperatures up to 80 °C
- reliable in portable systems

DZR Swing Check Valve

2622

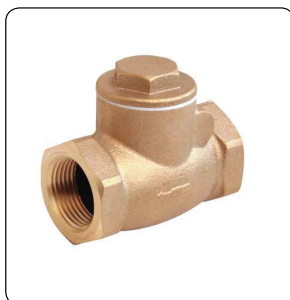

Order number	DN	PN
1 2622 41	15	25
1 2622 42	20	25
1 2622 43	25	25
1 2622 44	32	25
1 2622 45	40	25
1 2622 46	50	25

Description:

BS 5154 PN25
BS 21 (BSPP) threaded ends

Taps



- Brass
- Chromed
- Outlet with strainer
- Outlet distance 95 mm



- Brass
- Chromed
- Hose connection
- Outlet distance 95 mm



- Brass
- Chromed
- Hose connection
- Outlet distance 30 mm

Order number
U H100 52
U H101 51
U H101 52



Plastic Composite Pipe PE-RT



Order number	Aluminium wall thickness (mm)	Diameter Wall thickness (mm)	Item Rolls (m)
3 C160 20	0.4	16 x 2	200
3 C200 20	0.4	20 x 2	100
3 C260 30	0.5	26 x 3	50
3 C320 30	0.5	32 x 3	50
3 C400 30	0.5	40 x 3.5	50

Order number	Aluminium wall thickness (mm)	Diameter Wall thickness (mm)	Item Rolls (m)
3 C160 22	0.25	16 x 2	100
3 C200 30	0.25	20 x 2	100

Order number	Aluminium wall thickness (mm)	Diameter Wall thickness (mm)	Item Rolls (m)
3 C101 30	0.2	10 x 1.3	250
3 D160 20	0.2	16 x 2	200



Order number	Aluminium wall thickness (mm)	Diameter Wall thickness (mm)	Item Rods (m)
3 C160 34	0.4	16 x 2	5
3 C200 34	0.4	20 x 2	5
3 C260 35	0.5	26 x 3	5
3 C320 35	0.5	32 x 3	5
3 C400 36	0.5	40 x 3.5	5
3 C500 40	0.6	50 x 4	5
3 C630 45	0.8	63 x 4.5	5
3 C750 50	0.8	75 x 5	5

Plastic composite pipe PE-RT/Al/PE-RT. Multilayer pipe for complex installation tasks in heating, air conditioning and plumbing installations. System tested with HERZ-PIPEFIX press fittings or connectors. Delivered in coils. WRAS approved.

Plastic Composite Pipe PE-RT, with Insulation



Order number	Insulation wall thickness (mm)	Diameter Wall thickness (mm)	Item Rolls (m)
3 C160 06	6	16 x 2	100
3 C200 06	6	20 x 2	50
3 C260 06	6	26 x 3	50
3 C320 06	6	32 x 3	25
3 C160 09	9	16 x 2	100
3 C200 09	9	20 x 2	50
3 C260 09	9	26 x 3	50
3 C320 09	9	32 x 3	25
3 C160 13	13	16 x 2	50
3 C200 13	13	20 x 2	50
3 C260 13	13	26 x 3	25
3 C320 13	13	32 x 3	25

Heating and plumbing pipes with heat-insulation from LDPE foam with PP coating. Thermal conductivity of 0.04 W/mK as per DIN EN 8497. Reaction to fire according to DIN 4102 B1. CFC and HCFC free. Water vapor diffusion number ≥ 6000 to 52 615 DSIN. Outer casing white, black lettering.

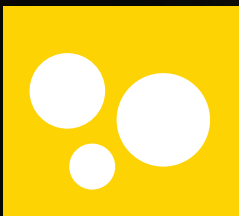

03/ Gas

Quality material, responsible use

GAS

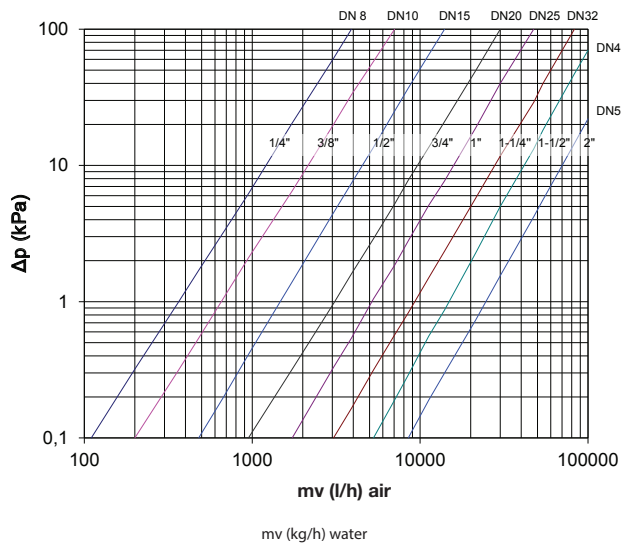
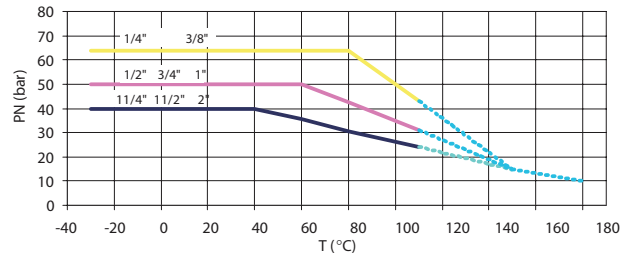
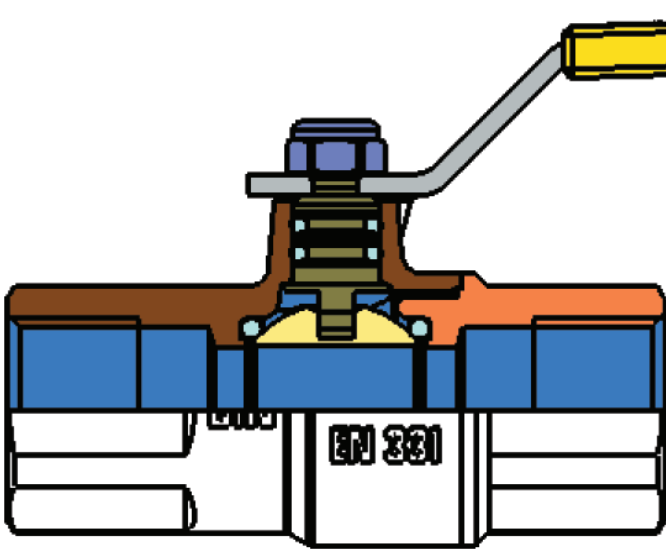

DN	8	10	15	20	25	32	40	50
Kv	3,9	7,1	17	34	55	102	165	270
Kvp	3,6	6,6	15,8	31,5	51	95	153	250

- Kv:** outflow characteristic (m³/h) - is the flow of water at temperature 15.5°C, a pressure drop of 1 bar (100 kPa) and a fully open valve.
- Kvp:** Outflow characteristic (m³/h) - is the flow of air with density of 1,16 kg/m³ at temperature 15.5°C, a pressure drop of 1 mbar (0,1 kPa) and a fully open valve.

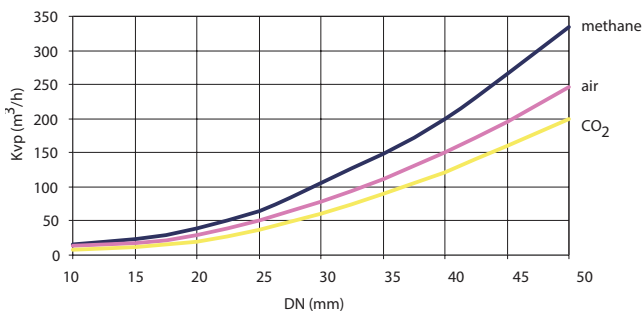

Ball valve for gas is a fitting with unreduced flow, which can be installed into the gas installations with low pressure (in accordance with DIN-DVGW - Table G. 260).

Field of application is in the systems where the medium are explosive combustible gases (natural gas, petroleum gas etc.) up to max. working pressure of 500 kPa (5 bar) and the temperature range of -20°C up to + 60°C (certified according to DIN-DVGW under No. 01-0504-GNE).

These valves are also suitable for general usage (also for other mediums – oil, water, air...) due to standard construction design. In this case, the temperature range is from -20°C up to + 110°C (water 0°C up to 110 °C) and working pressure up to max. 2500 kPa (25 bar) – according to the PN-T diagram.

In case of fire, ball valves that have integrated TAS cartridge are sealed up to 925°C for at least one hour.

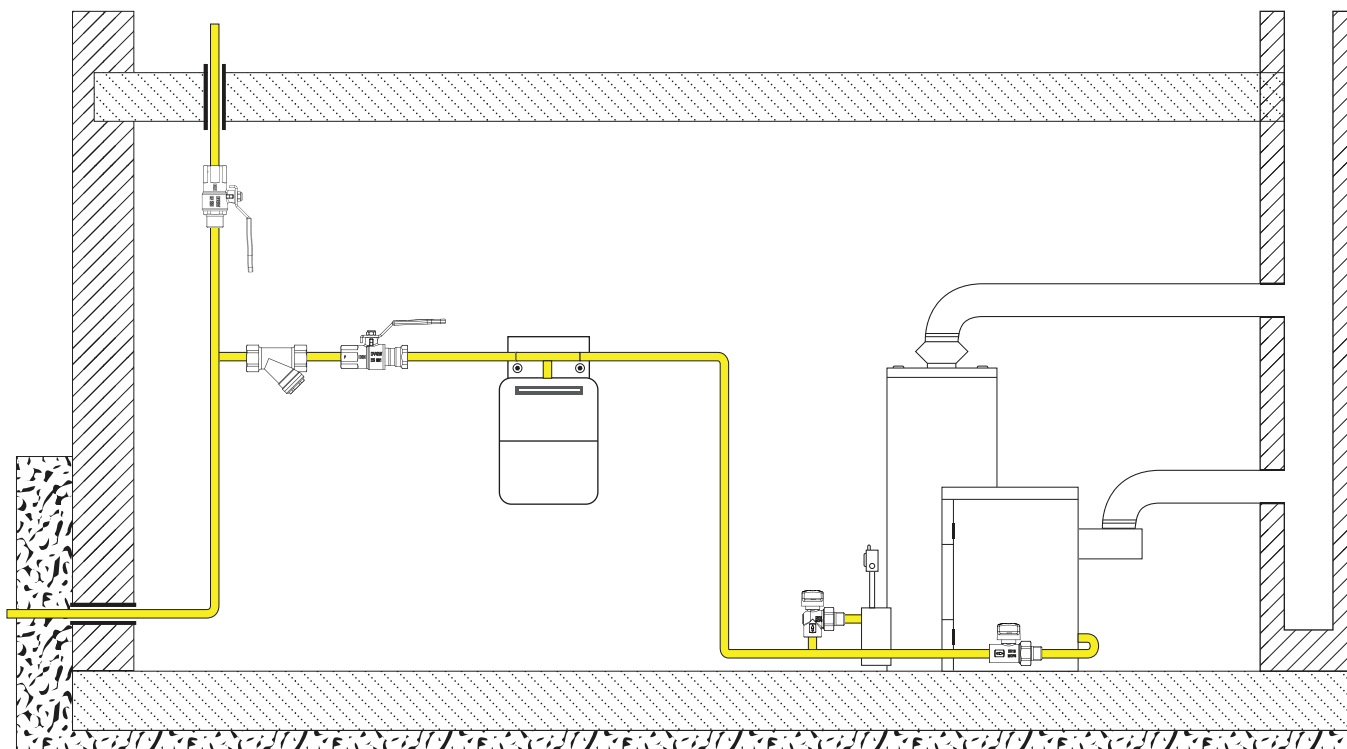

HVAC

Ball Valve for gas

2300 with steer level



2300 with steel T-handle

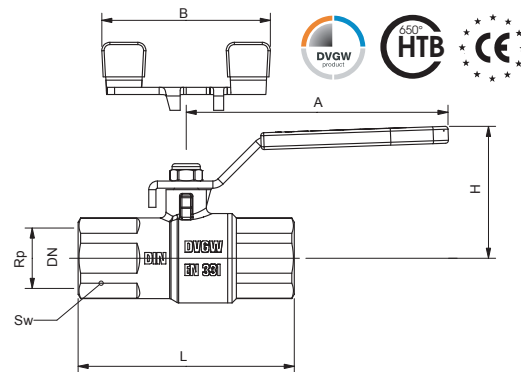

Water

Order number	MOP	PN*	DN	Rp	L	A	B	H	Sw		
1 2300 09	5	1	8								
1 2300 00	5	1	10								
1 2300 01	5	1	15	1/2"	75	90	-	43	26	0.275	25
1 2300 02	5	1	20	3/4"	80	90	-	47	32	0.395	25
1 2300 03	5	1	25	1"	90	135	-	72	41	0.725	20
1 2300 04	5	1	32	1 1/4"	110	135	-	75	50	1.175	16
1 2300 05	5	1	40	1 1/2"	120	180	-	82	55	1.830	8
1 2300 06	5	1	50	2"	140	180	-	89	70	3.000	4
1 2300 19	5	1	8								
1 2300 10	5	1	10								
1 2300 11	5	1	15	1/2"	75	-	60	43	26	0.275	25
1 2300 12	5	1	20	3/4"	80	-	60	47	32	0.395	25
1 2300 13	5	1	25	1"	90	-	85	72	41	0.725	20
1 2300 14	5	1	32	1 1/4"	110	-	85	75	50	1.175	16

T = -20 °C...+60 °C

**HTB 650 °C - fireproof (30 min)

Gas

GAS

Ball Valve for gas

2301 with steer level



2301 with steel T-handle

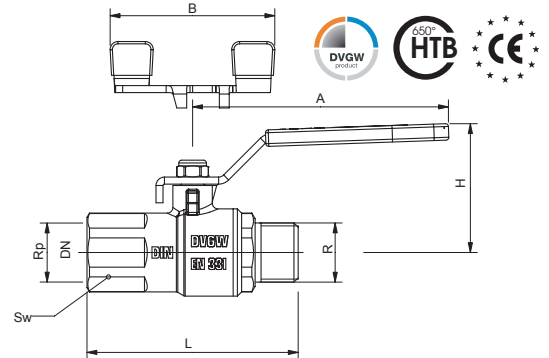

Order number	MOP	PN*	DN	Rp - R	L	A	B	H	Sw
1 2301 09	5	1	8	1/4"	55	70	-	41	17
1 2301 00	5	1	10	3/8"	60	70	-	41	21
1 2301 01	5	1	15	1/2"	75	90	-	43	26
1 2301 02	5	1	20	3/4"	80	90	-	47	32
1 2301 03	5	1	25	1"	90	135	-	61	41
1 2301 04	5	1	32	1 1/4"	110	135	-	66	50
1 2301 05	5	1	40	1 1/2"	120	180	-	86	55
1 2301 06	5	1	50	2"	140	180	-	90	70
1 2301 19	5	1	8	1/4"	55	-	60	41	17
1 2301 10	5	1	10	3/8"	60	-	60	41	21
1 2301 11	5	1	15	1/2"	75	-	60	43	26
1 2301 12	5	1	20	3/4"	80	-	60	47	32
1 2301 13	5	1	25	1"	90	-	85	61	41
1 2301 14	5	1	32	1 1/4"	110	-	85	66	50

T = -20 °C...+60 °C

*HTB 650 °C - fireproof (30 min)

Ball valves for gas

2302 with steel lever



2302 with steel T-handle

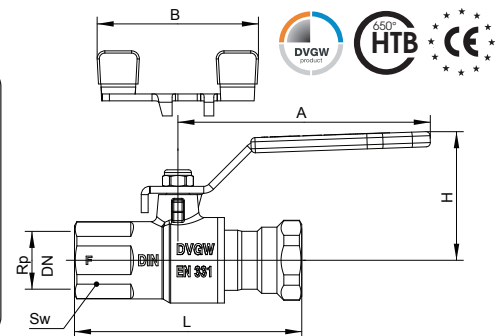
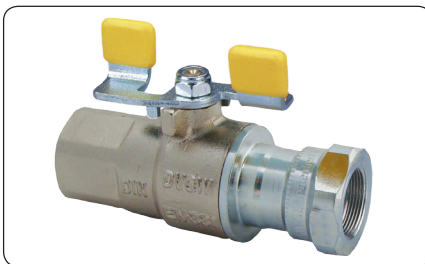

Order number	MOP	PN*	DN	Rp	L	A	B	H	Sw		
1 2302 01	5	1	15	1/2"	98	90	-	45	26	0.400	25
1 2302 02	5	1	20	3/4"	107	90	-	49	32	0.600	25
1 2302 03	5	1	25	1"	133	135	-	66	41	1.250	20
1 2302 11	5	1	15	1/2"	98	-	60	45	26	0.400	25
1 2302 12	5	1	20	3/4"	107	-	60	49	32	0.600	25
1 2302 13	5	1	25	1"	133	-	85	66	41	1.250	20

T = -20 °C...+60 °C

*HTB 925 °C - fireproof (60 min)



Ball Valve for gas

2303 with steer level



2303 with steel T-handle

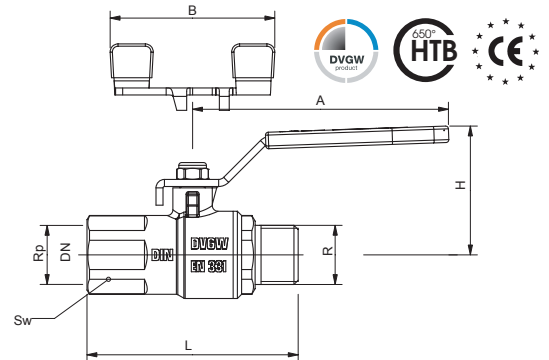

Order number	MOP	PN*	DN	Rp - R	L	A	B	H	Sw		
1 2303 09	5	1	8								
1 2303 00	5	1	10								
1 2303 01	5	1	15	1/2"	75	90	-	47	26	0.275	25
1 2303 02	5	1	20	3/4"	80	90	-	49	32	0.395	25
1 2303 03	5	1	25	1"	90	135	-	66	41	0.725	20
1 2303 04	5	1	32	1 1/4"	110	135	-	69	50	1.175	16
1 2303 05	5	1	40	1 1/2"	120	180	-	85	55	1.830	8
1 2303 06	5	1	50	2"	137	180	-	90	70	3.000	4
1 2303 19	5	1	8								
1 2303 10	5	1	10								
1 2303 11	5	1	15	1/2"	75	-	60	47	26	0.275	25
1 2303 12	5	1	20	3/4"	80	-	60	49	32	0.395	25
1 2303 13	5	1	25	1"	90	-	85	66	41	0.725	20
1 2303 14	5	1	32	1 1/4"	110	-	85	69	50	1.175	16

T = -20 °C...+60 °C

*HTB 650 °C - fireproof (30 min)

GAS

Ball Valve for connecting devices, straightway

2362

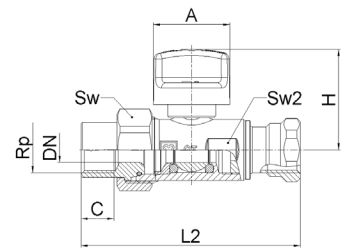
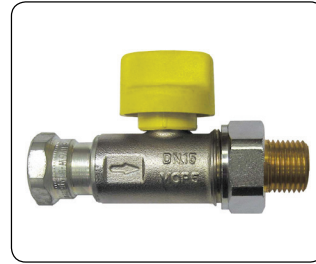
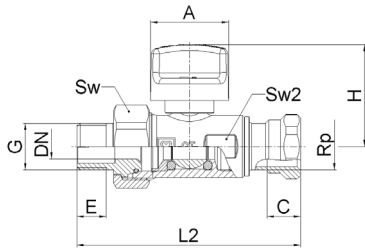

Order number	DN	MOP	PN*	Rp	G	L2	C	E	A	H	Sw	Sw2	👤	📦
1 2362 21	15	5	1	1/2	1/2	100	15	13.2	35	46	34	26	0.322	25
1 2362 22	15	5	1	1/2	-	100	15	-	35	46	34	26	0.330	25
1 2362 23	20	5	1	3/4	-	112	16.3	-	35	49	41	30	0.432	25
1 2362 31	25	5	1	1	-	130	19.1	-	35	52	48	37	0.719	16



Ball Valve for connecting devices, straightway

2363

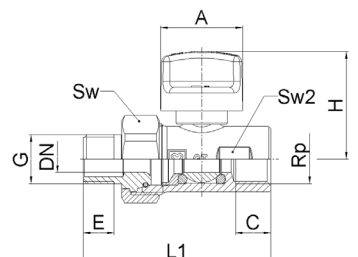
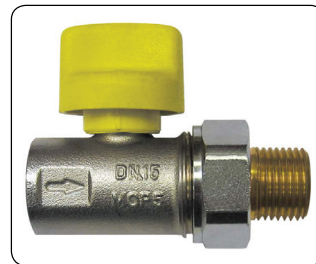
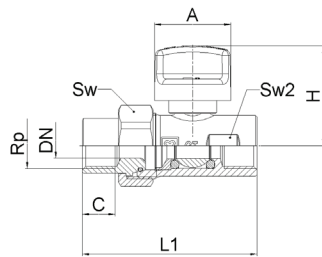

Order number	DN	MOP	PN*	Rp	G	L1	C	E	A	H	Sw	Sw2	👤	📦
1 2363 01	15	5	1	1/2	1/2	100	15	13.2	35	46	34	26	0.288	25
1 2363 11	15	5	1	1/2	-	100	15	13.2	35	46	34	26	0.295	25

T = -20 °C...+60 °C

*HTB 650 °C - fireproof (30 min)



Ball Valve for connecting devcies, angle

2362

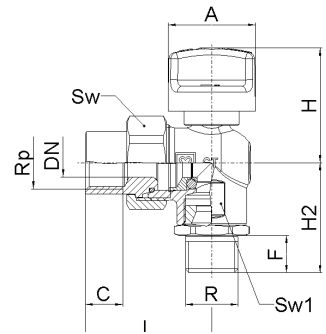
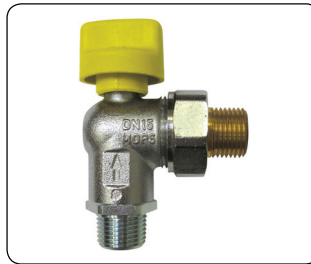
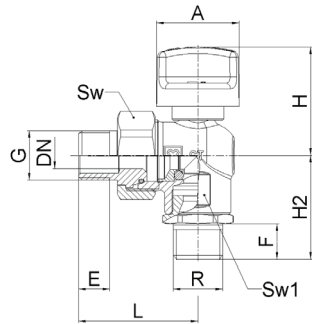

Order number	DN	MOP	PN*	G	Rp	L	C	E	F	A	H	H2	Sw	Sw1		
1 2362 41	15	5	1	1/2	1/2	51	15	13.2	15	35	46	44	34	26	0,309	25
1 2362 42	15	5	1	-	1/2	51	15	-	15	35	46	44	34	26	0,309	25
1 2362 43	20	5	1	-	3/4	57	16,3	-	16.3	35	49	49	41	30	0,449	25
1 2362 51	25	5	1	-	1	70	19,1	-	19.1	35	52	57	48	37	0,738	16



T = -20 °C...+60 °C

*HTB 650 °C - fireproof (30 min)

HVAC

Ball Valve for connecting devcies, angle

2363

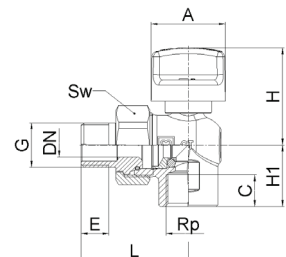
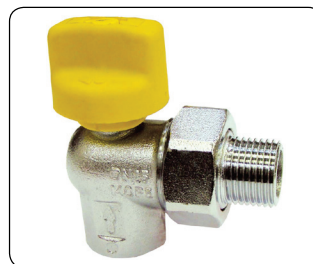
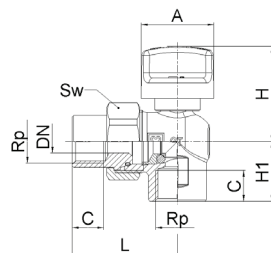

Order number	DN	MOP	PN*	Rp	G	L	C	E	F	A	H	H1	Sw		
1 2363 21	15	5	1	1/2	1/2	51	15	13.2	15	35	46	29	34	0,309	25
1 2363 31	15	5	1	1/2	-	51	15	13.2	15	35	46	29	34	0,309	25



T = -20 °C...+60 °C

*HTB 650 °C - fireproof (30 min)

Water

Gas

GAS

Ball Valve with security closing T-handle

2362

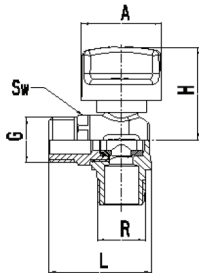

2372

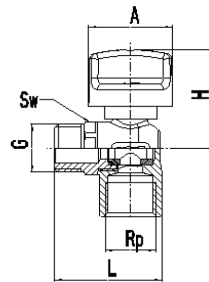

Order number	DN	MOP	PN*	G	Rp	L	A	H	Mt (Nm)	Sw
1 2362 00	10	5	1	1/2	1/2	44	35	43	75	21
1 2372 01	10	5	1	1/2	1/2	44	35	43	75	21

T = -20 °C...+60 °C

*HTB 650 °C - fireproof (30 min)

Ball Valve with duraluminium T-handle

2362

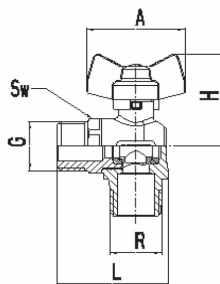

2372

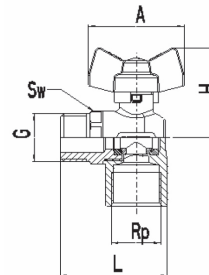

Order number	DN	MOP	PN*	G	Rp	L	A	H	Mt (Nm)	Sw
1 2362 10	10	5	1	1/2	1/2	44	40	39	75	21
1 2372 11	10	5	1	1/2	1/2	44	40	39	75	21

T = -20 °C...+60 °C

*HTB 925 °C - fireproof (60 min)



Accessories

Insulating Nipple for gas

2000

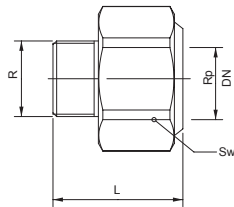
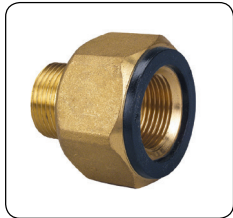

Order number	PN	DN	Rp	L	Sw		
1 2000 02	5	20	3/4"	45	46	0.250	1

T = -20 °C...+60 °C

Strainer for gas

2319

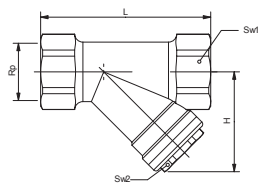

Order number	PN	Rp	L	Sw1	Sw2	H		Kvp		
1 2319 01	5	1/2"	68	25	22	37	0.050	2.30	0.170	1
1 2319 02	5	3/4"	80	32	24	46	0.050	4.20	0.280	1
1 2319 03	5	1"	90	41	25	55	0.050	6.80	0.510	1

T = -20 °C...+60 °C

Pipes for gas

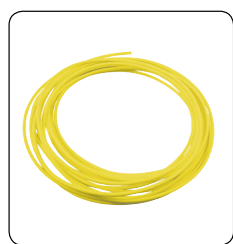

Order number	PN	Diameter Wall thickness (mm)	Item Rolls (m)
G 1160 20	0.1	16 x 2	200
G 1200 20	0.1	20 x 2	100
G 1260 20	0.1	26 x 3	50
G 1320 20	0.1	32 x 3	50

Aluminium core, in reels 50 metres, with yellow extra strong surface RAL 1201. Operating temperature -20 °C to +60 °C, max. Operating pressure 100 mbar.



Order number	PN	Diameter Wall thickness (mm)	Item Rolls (m)
G 1160 21	0.1	16 x 2	120
G 1200 21	0.1	20 x 2	120
G 1260 21	0.1	26 x 3	120
G 1320 21	0.1	32 x 3	50

Aluminium core, in 5 metre length, with yellow extra strong surface RAL 1201. Operating temperature -20 °C to +60 °C, max. Operating pressure 100 mbar.

Lined area for notes, consisting of multiple horizontal gray bars.

Lined area for notes, consisting of multiple horizontal gray bars.

Certificate of Guarantee

1. Definition of Terms and Scope of Validity

- 1.1. In order to be entitled to claim services under the present Certificate of Guarantee, the claiming party must hold a trade licence for the installation of low-pressure central heating systems and hot water preparation plants of the upper and lower categories or a trade licence for gas fitters and plumbers.
- 1.2. Under the present Certificate of Guarantee „Products“ shall designate all heating components manufactured by us after May 1, 2015, bought new by the party entitled to raise a claim either directly from us or directly from one of our authorized dealers in Austria, unless these components have been exempted from the validity of the Certificate of Guarantee by express declaration to the party entitled to raise a claim or are generally exempted from such guarantee. There are special provisions for electronic and electric products such as HERZ-Electronic thermostats and actuating drives, HERZ-Actuating drives, HERZ-Room temperature controllers, HERZ transformers and wireless control systems and devices, which are not covered by the Certificate of Guarantee. Furthermore, wear parts of HERZ components such as seals are not covered by the present Certificate of Guarantee.
- 1.3. A case of damage in the sense of the Certificate of Guarantee occurs when a customer of a party entitled to raise claims with HERZ raises a warranty claim against the said party for any damage caused by an error in design or a defect in manufacturing or materials of the products.
- 1.4. The geographic validity of the Certificate of Guarantee shall be limited to places within Europe.

2. Extend of Services rendered under the Certificate of Guarantee

We shall render the following services under the present Certificate of Guarantee (excluding any further claims):

- 2.1. Replacement free of charge of the products or product components required repairing the damage, free place of damage.
- 2.2. According to our choice:
 - a) performing the required dismantling /disassembly and assembly/ installation of products or product components or
 - b) repairing the initial products or product components or
 - c) paying the costs for the services as mentioned above.
- 2.3. Repairing the immediate material damage caused by the defective products or paying the costs for the services as mentioned above.
- 2.4. Damages for direct personal injury caused by the defective products.
- 2.5. Our liability according 2.1. to 2.3. is limited to € 500,000 per claim.
- 2.6. Without prejudice to the provisions of item 4.1. our liability shall be limited in terms of time to claims arising within a period of 5 years after manufacturing of the products causing the damage.

- 2.7. Our liability is limited to claims arising out of errors in design, defects in manufacturing or materials of the products and based on the absence of characteristics which have either been guaranteed by us or which can be expected in accordance with the state of technology or with trade practice.

3. Obligations of the Party Entitled to Raise Claims

It is a condition precedent for the implementation of the present Certificate of Guarantee that the party entitled to raise claims meet the below mentioned obligations. Failure to meet any or several of these obligations shall relieve HERZ of any and all obligations under the present Guarantee.

- 3.1. During installation and use of the products it is imperative to observe our instructions for installation and maintenance valid at the moment of installation and laid down in the brochures, standard sheets, as well as our information regarding the scope of application of the products. Furthermore, it is imperative to proceed with due care according to the state of technology, particularly during maintenance.
- 3.2. As soon as the party entitled to raise a claim detects or learns of a case of damage, it shall forthwith inform HERZ of such damage (not later than on the 3rd working day thereafter) by fax, telex or cable and shall make available to us all information requested by us. The information shall be submitted in writing upon our request.
- 3.3. The party entitled to raise a claim shall make sure that the representatives of our company and the agents of our insurance company be granted access to the place of damage immediately after giving notice of the claim and shall take all appropriate measures to determine the cause and scope of the damage. In particular, the party entitled to raise a claim shall keep and make available the products or product components which caused the damage.
- 3.4. The burden of proof lies with the party who suffered the damage. The party entitled to raise a claim shall not acknowledge any obligation to damages neither with regard to its basis nor to its extent, neither in its own name nor on our behalf. Any declaration extending the scope of damages offered by the present Certificate of Guarantee and by the applicable legal provisions made by the party entitled to raise a claim before or after the occurrence of damage, are not admitted and shall not be binding on us.

4. Period of Validity and Formal Provisions

- 4.1. The present Certificate of Guarantee shall cover claims for damage occurring between May 1, 2015 and April 30, 2020. We reserve the right to extend this period.
5. Place of Fulfilment, Jurisdiction, Applicable Law
- 5.1. The place of fulfilment shall be Vienna. The court having subject-matter jurisdiction for our company in Vienna shall have exclusive jurisdiction. Any disputes arising from the present Certificate of Guarantee shall be settled according to Austrian Law. The application of the UN-Convention on Contracts for the International Sale of Goods is expressly excluded.

Vienna, May 2015



Terms and Conditions of Sale, Delivery and Payment

1. Offers, Acknowledgement of Orders, Conclusion of Contracts

- 1.1. All offers are without obligation. We reserve the right to modify, supplement or discontinue our production at any time. We are entitled to accept only partial orders or to refuse them without giving a reason.
- 1.2. Our written acknowledgement of order constitutes a contract, an acknowledgement of order by facsimile is sufficient also. The content of the acknowledgement of order shall at the same time be the content of the contract unless the customer raises an objection against it immediately after receipt. Otherwise, our acknowledgement of order and our Terms and Conditions of Sale, Delivery and Payment shall be deemed to have been accepted. In case of claim against the order confirmation, its content becomes a contract if the customer accepts the delivery and/or makes a payment.
- 1.3. After the acknowledgement of order has been sent, the order placed with us no longer can be changed or cancelled.
- 1.4. The present Terms and Conditions of Sale, Delivery and Payment shall supersede any purchasing conditions of our customers in any case. They also apply to any future business with the customer.
- 1.5. Prices are understood to be from the factory, unpackaged, carriage forward and without VAT.
- 1.6. In case of an increase in costs during the period between the acknowledgement of order and delivery, we shall be entitled to make the respective price adjustments.
- 1.7. In case that a component of a fitting ordered is not needed, the price deduction shall not be made according to the component price but according to our price calculation.
- 1.8. Declarations and announcements of HERZ towards our contract partners come into force with sending these declarations and announcements to the mailing address known to us. This is also valid if the mailing address has been changed and has not been announced immediately.
- 1.9. To be considered valid, changes and additions to the contract must be agreed and confirmed in writing by persons with representative status who are entered in the company register of our firm. Our other staff are not authorised to arrange changes or additional agreements.

2. Conditions of Payment

- 2.1. As long as nothing else is given in the order confirmation, payments are net cash at receipt of the invoice and without any discount.
- 2.2. In case of default payment we reserve the right to demand payment of default interest at a rate of 10% above the then current Austrian bank rate (per year), however not less than 1% per month. Only payments made to the payment entity specify in the invoice will be recognised. In case of bank transfers, payment shall be deemed to have been made only when the amount of the invoice has been irrevocably credited to our account.
- 2.3. Bills of exchange, cheques and payments by money order will be recognised only on account of payment. In this event a discount is not permitted even for special discount arrangements.
- 2.4. In case of payment by accepted bill or customer's bill, the discount charges shall be borne by the debtor.
- 2.5. The date of the invoice shall be relevant for the date of payment in any case, even if goods are received with a delay for reasons not to be attributed to us.
- 2.6. In the event that payment is not made by the due date or in case of deteriorating financial soundness of the customer or on other important reasons, we shall be entitled at our discretion to repudiate the contract or to demand immediate payment of any and all debts irrespective of the term of payment agreed upon, all this without any claim for fulfilment or damages arising against us.

3. Retention of Title

- 3.1. The goods supplied by us shall remain our property until payment in full has been made for any and all goods supplied. This shall also apply to the payment of any bills of exchange accepted in payment by us. In the event of re-sale for cash, the re-sale proceeds from this separate retention by the customer come to us and oblige the customer to enter a valid note in the accounts (anticipated ownership). In the case of manufacturing our retention of title (proportionate) is the end product. The customer must inform their buyer at re-sale about the existing retention of title and all other security laws agreed.
- 3.2. The buyer must inform us immediately if third parties raise claims against our goods supplied under our retention of title or bring legal actions. Any costs resulting from legal consequences are to be borne by the buyer.

4. Packing and Dispatch

- 4.1. The goods will be packed to commercial standards at the buyer's expense. Packing materials will not be taken back. The packing shall be dimensioned assuming customary transport conditions.
- 4.2. The goods will be dispatched ex-works at the risk of the buyer, even in case of delivery freight prepaid.
- 4.3. The seller shall be obliged to take out insurance only if and to the extent that this has been agreed upon in writing.

5. Modification of Models

- 5.1. We reserve the right to make design modifications, to change tolerances and to make improvements.
- 5.2. In case of special designs manufactured according to customer sample, model or drawing, we reserve the right to supply up to 5% more or less than the quantity ordered.

6. Complaints

- 6.1. With regard to any defects or damage that can be recognised during proper inspection upon receipt, not recognizable defects or damages have to be repohend immediately after their occurrence, a complaint shall be filed immediately after receipt of goods. However, any warranty claim shall expire three months after delivery.
- 6.2. In addition, in case of deviations in the number of units supplied or in weight, a complaint shall be filed with the railway company or the forwarding agent (carrier) upon receipt of the goods, and a certification to support any such difference shall be obtained. Any defective units shall be returned to us without delay freight prepaid.

7. Warranty

- 7.1. We will perform our warranty obligation by replacing free of charge any items which become totally inoperative within a period of three months as a result of defective materials or deficiencies in workmanship, provided that the rejected items are returned within 4 months from delivery.

8. Returned Goods

- 8.1. Returned goods will only be accepted with our prior written consent and only if sent free our works in Vienna without any damage or defect.
- 8.2. Return of items made to order will not be accepted in any case.

9. Default in Delivery and Release from the Delivery Commitment

- 9.1. The obligation to deliver and to adhere to the delivery period shall be suspended by any extraordinary events and circumstances not to be attributed to us which causes a relevant interruption of operations or makes the dispatch of goods impossible.
- 9.2. In the event that dispatching of goods is impossible, we shall be entitled to store any goods already manufactured at the expense and risk of the buyer. In that case, the goods will be invoiced to the buyer as if they had already been supplied.
- 9.3. If we are in default in delivery, the buyer shall grant a reasonable period of grace of not less than 6 weeks. The buyer shall not be entitled to cancel the contract after we have initiated production of the goods ordered – even after having granted a period of grace.

10. Quality of a Consignment

- 10.1. The quality of a consignment cannot be assessed on the basis of the quality of individual items.

11. Damages, Limitation of Warranty

- 11.1. The amount of any claims is limited according to the net invoice value of the item in question.
- 11.2. We are entitled to settle any guarantee claims through the provision of replacement parts. No claims can be made for price reductions.
- 11.3. We shall not recognise or reimburse any claims for damages with respect to installation costs, incipient processing costs, maintenance costs, etc. in any case.
- 11.4. Claims for damages by the customer are excluded, whatever the legal reasons, particularly due to delays, impossibility of attainment, positive breach of a claim, debts at conclusion of a contract, damage consequential to defects and defects due to improper handling, as long as they are intentional or do to gross negligence on our part. In the event of intent or gross negligence the customer must give proof of this. Information issued by us (installation and maintenance instructions, details of areas of use for products, etc.) must be strictly adhered to. Where instructions are disregarded or ignored, the official conditions release us from any liability.
- 11.5. We do not assume liability for any loss or damage resulting from improper handling or use, overstraining or natural wear. Furthermore, we do not assume liability with respect to any loss or damage caused by negligence nor any indirect or consequential loss.
- 11.6. Our liability for material damage due to a production fault according to the Product Liability Act (Produkthaftungsgesetz) shall be excluded for all companies participating in the production and distribution of our products, as well as for all buyers of our products who are entrepreneurs. The parties to contracts with us who are entrepreneurs undertake to transfer this exoneration clause to their customers to the extent that they on their part are entrepreneurs and as far as our products are concerned.

12. Place of Fulfilment and Jurisdiction

- 12.1. The place of fulfilment for all contract demands shall be Vienna, if the product is taken from Vienna factory; if the product is taken from Kemeten factory, Kemeten is a place of fulfilment.
- 12.2. For partners from the European Union countries as well as from the European Economic Area and for the partners with headquarter situated in a country, which has an enforcement agreement with Austria the court having subjectmatter jurisdiction in Vienna is agreed as a place of fulfilment for all contract demands.
- 12.3. For the partners from countries, which do not fall under the point 12.2 the court having subjektmatter jurisdiction in Vienna is agreed as a place of fulfilment. HERZ reserves the right to sue for the contract demand in each case in the responsible court.
- 12.4. In subsidiarity to these Terms and Conditions of Sale, Delivery and Payment, Austrian legal provisions are to be applied exclusively. The application of the UN-Convention on Contracts for the International Sale of Goods is expressly excluded.



Selection Matrix for Actuators

			F 7712 90 24 V modulating 500 N, 15 mm	F 7712 91 24 V modulating 1000 N, 20 mm	F 7712 92 24 V modulating 2500 N, 40 mm	F 7712 93 24 V modulating 1500 N, 20 mm	F 7712 94 24 V modulating 12000 N, 65 mm	F 7712 95 24 V open-close, 3 Pt. 500 N, 15 mm
Combi Valves	DN	kvs						
F 4006 71 F 4006 90	15	2,5	<input checked="" type="checkbox"/>					<input checked="" type="checkbox"/>
F 4006 72 F 4006 91	15	4	<input checked="" type="checkbox"/>					<input checked="" type="checkbox"/>
F 4006 73 F 4006 92	25	6,3	<input checked="" type="checkbox"/>					<input checked="" type="checkbox"/>
F 4006 93 F 4006 53	25	8	<input checked="" type="checkbox"/>					<input checked="" type="checkbox"/>
F 4006 74 F 4006 94	32	12	<input checked="" type="checkbox"/>					<input checked="" type="checkbox"/>
F 4006 75 F 4006 95 F 4006 61	40	20		<input checked="" type="checkbox"/>				
F 4006 80 F 4006 96 F 4006 62	50	32		<input checked="" type="checkbox"/>				
F 4006 81 F 4006 97 F 4006 63	65	50			<input checked="" type="checkbox"/>			
F 4006 82 F 4006 98 F 4006 64	80	80			<input checked="" type="checkbox"/>			
F 4006 83 F 4006 99 F 4006 65	100	125			<input checked="" type="checkbox"/>			
F 4006 84 F 4006 10 F 4006 66	125	180			<input checked="" type="checkbox"/>			
F 4006 39	15	1,6	<input checked="" type="checkbox"/>					<input checked="" type="checkbox"/>
F 4006 40	15	2,5	<input checked="" type="checkbox"/>					<input checked="" type="checkbox"/>
F 4006 41	15	4	<input checked="" type="checkbox"/>					<input checked="" type="checkbox"/>
F 4006 42	20	6,3	<input checked="" type="checkbox"/>					<input checked="" type="checkbox"/>
2-Port Valves								
F 4035 01 F 4035 40	15	1	<input checked="" type="checkbox"/>					<input checked="" type="checkbox"/>
F 4035 11 F 4035 51	15	1,6	<input checked="" type="checkbox"/>					<input checked="" type="checkbox"/>
F 4035 21 F 4035 61	15	2,5	<input checked="" type="checkbox"/>					<input checked="" type="checkbox"/>
F 4035 31 F 4035 71	15	4	<input checked="" type="checkbox"/>					<input checked="" type="checkbox"/>
F 4035 03 F 4035 43	25	6,3	<input checked="" type="checkbox"/>					<input checked="" type="checkbox"/>
F 4035 13 F 4035 53	25	10	<input checked="" type="checkbox"/>					<input checked="" type="checkbox"/>
F 4035 04 F 4035 44	32	16		<input checked="" type="checkbox"/>				
F 4035 05 F 4035 45	40	25		<input checked="" type="checkbox"/>				
F 4035 06 F 4035 46	50	40			<input checked="" type="checkbox"/>			
F 4035 16 F 4035 56	50	40				<input checked="" type="checkbox"/>		
F 4035 07 F 4035 47	65	63			<input checked="" type="checkbox"/>			
F 4035 08 F 4035 48	80	100			<input checked="" type="checkbox"/>			
F 4035 09 F 4035 49	100	160			<input checked="" type="checkbox"/>			
F 4035 10 F 4035 50	125	250					<input checked="" type="checkbox"/>	
F 4035 41 F 4035 52	150	330					<input checked="" type="checkbox"/>	
3-Port Valves								
F 4037 01	15	1	<input checked="" type="checkbox"/>					<input checked="" type="checkbox"/>
F 4037 11	15	1,6	<input checked="" type="checkbox"/>					<input checked="" type="checkbox"/>
F 4037 21	15	2,5	<input checked="" type="checkbox"/>					<input checked="" type="checkbox"/>
F 4037 31	15	4	<input checked="" type="checkbox"/>					<input checked="" type="checkbox"/>
F 4037 03	25	6,3	<input checked="" type="checkbox"/>					<input checked="" type="checkbox"/>
F 4037 13	25	10	<input checked="" type="checkbox"/>					<input checked="" type="checkbox"/>
F 4037 04	32	16		<input checked="" type="checkbox"/>				
F 4037 05	40	25		<input checked="" type="checkbox"/>				
F 4037 06	50	40			<input checked="" type="checkbox"/>			
F 4037 16	50	40				<input checked="" type="checkbox"/>		
F 4037 07	65	63			<input checked="" type="checkbox"/>			
F 4037 08	80	100			<input checked="" type="checkbox"/>			
F 4037 09	100	160			<input checked="" type="checkbox"/>			
F 4037 10	125	250					<input checked="" type="checkbox"/>	
F 4037 41	150	330					<input checked="" type="checkbox"/>	

*Combination of Valve and Actuator available from Q1/2015.

Selection Matrix for Actuators

F 7712 96 24 V open-close, 3 Pt. 1000 N, 20 mm	F 7712 97 24 V open-close, 3 Pt. 1500 N, 20 mm	F 7712 98 24 V open-close, 3 Pt. 2500 N, 40 mm	F 7712 81 230 V open-close, 3 Pt. 500 N, 15 mm	F 7712 82 230 V open-close, 3 Pt. 1000 N, 20 mm	F 7712 83 230 V open-close, 3 Pt. 1500 N, 20 mm	F 7712 84 230 V open-close, 3 Pt. 2500 N, 40 mm	F 7712 85 230 V open-close, 3 Pt. 12000 N, 65 mm
			<input checked="" type="checkbox"/>				
			<input checked="" type="checkbox"/>				
			<input checked="" type="checkbox"/>				
			<input checked="" type="checkbox"/>				
			<input checked="" type="checkbox"/>				
<input checked="" type="checkbox"/>				<input checked="" type="checkbox"/>			
<input checked="" type="checkbox"/>				<input checked="" type="checkbox"/>			
		<input checked="" type="checkbox"/>				<input checked="" type="checkbox"/>	
		<input checked="" type="checkbox"/>				<input checked="" type="checkbox"/>	
		<input checked="" type="checkbox"/>				<input checked="" type="checkbox"/>	
		<input checked="" type="checkbox"/>				<input checked="" type="checkbox"/>	
			<input checked="" type="checkbox"/>				
			<input checked="" type="checkbox"/>				
			<input checked="" type="checkbox"/>				
			<input checked="" type="checkbox"/>				
			<input checked="" type="checkbox"/>				
			<input checked="" type="checkbox"/>				
<input checked="" type="checkbox"/>				<input checked="" type="checkbox"/>			
<input checked="" type="checkbox"/>				<input checked="" type="checkbox"/>			
		<input checked="" type="checkbox"/>				<input checked="" type="checkbox"/>	
	<input checked="" type="checkbox"/>				<input checked="" type="checkbox"/>		
		<input checked="" type="checkbox"/>				<input checked="" type="checkbox"/>	
		<input checked="" type="checkbox"/>				<input checked="" type="checkbox"/>	
		<input checked="" type="checkbox"/>				<input checked="" type="checkbox"/>	
							<input checked="" type="checkbox"/>
							<input checked="" type="checkbox"/>
			<input checked="" type="checkbox"/>				
			<input checked="" type="checkbox"/>				
			<input checked="" type="checkbox"/>				
			<input checked="" type="checkbox"/>				
			<input checked="" type="checkbox"/>				
			<input checked="" type="checkbox"/>				
<input checked="" type="checkbox"/>				<input checked="" type="checkbox"/>			
<input checked="" type="checkbox"/>				<input checked="" type="checkbox"/>			
		<input checked="" type="checkbox"/>				<input checked="" type="checkbox"/>	
	<input checked="" type="checkbox"/>				<input checked="" type="checkbox"/>		
		<input checked="" type="checkbox"/>				<input checked="" type="checkbox"/>	
		<input checked="" type="checkbox"/>				<input checked="" type="checkbox"/>	
		<input checked="" type="checkbox"/>				<input checked="" type="checkbox"/>	
							<input checked="" type="checkbox"/>
							<input checked="" type="checkbox"/>
			<input checked="" type="checkbox"/>				
		<input checked="" type="checkbox"/>				<input checked="" type="checkbox"/>	
		<input checked="" type="checkbox"/>				<input checked="" type="checkbox"/>	
		<input checked="" type="checkbox"/>				<input checked="" type="checkbox"/>	
							<input checked="" type="checkbox"/>
							<input checked="" type="checkbox"/>

Selection Matrix for Actuators

		Herz Bez.	1 7712 29 24 V stetig, 2-3 Pkt. 500 N, 20 mm	1 7712 31 24 V stetig, 2-3 Pkt. 1000 N, 20 mm	1 7712 32 24 V stetig, 2-3 Pkt. 2500 N, 40 mm	1 7712 21 24 V stetig, 2-3 Pkt. 2500 N, 40 mm
Kombiventil						
F 4006 71	15	2,5	1 7712 20 *			
F 4006 90			1 7712 20 *			
F 4006 72	15	4	1 7712 20 *			
F 4006 91			1 7712 20 *			
F 4006 73			1 7712 20 *			
F 4006 92			1 7712 20 *			
F 4006 93	25	6,3	1 7712 20 *			
F 4006 53			1 7712 20 *			
F 4006 74	32	12	1 7712 20 *			
F 4006 94			1 7712 20 *			
F 4006 75	40	20	1 7712 20 *			
F 4006 95			1 7712 20 *			
F 4006 61			1 7712 20 *			
F 4006 80			1 7712 20 *			
F 4006 96	50	32	1 7712 20 *			
F 4006 62			1 7712 20 *			
F 4006 81	65	50		1 7712 18 *		
F 4006 97			1 7712 18 *			
F 4006 63			1 7712 20 *			
F 4006 82	80	80		1 7712 18 *		
F 4006 98			1 7712 18 *			
F 4006 64			1 7712 17 *			
F 4006 83	100	125				direkte Montage
F 4006 99						direkte Montage
F 4006 65			1 7712 17 *			
F 4006 84	125	180				direkte Montage
F 4006 10						direkte Montage
F 4006 66						direkte Montage
F 4006 56			125			direkte Montage
F 4006 67			150			direkte Montage
F 4006 57			150			direkte Montage
F 4006 68			200			direkte Montage
F 4006 69			250			direkte Montage
F 4006 85			150			direkte Montage
F 4006 11			150			direkte Montage
F 4006 39			15	1,6	1 7712 20 *	
F 4006 40	15	2,5	1 7712 20 *			
F 4006 41	15	4	1 7712 20 *			
F 4006 42	20	6,3	1 7712 20 *			
2-Wege Ventile						
F 4035 01	15	1	1 7712 20 *			
F 4035 40			1 7712 20 *			
F 4035 11	15	1,6	1 7712 20 *			
F 4035 51			1 7712 20 *			
F 4035 21	15	2,5	1 7712 20 *			
F 4035 61			1 7712 20 *			
F 4035 31	15	4	1 7712 20 *			
F 4035 71			1 7712 20 *			
F 4035 03	25	6,3	1 7712 20 *			
F 4035 43			1 7712 20 *			
F 4035 13	25	10	1 7712 20 *			
F 4035 53			1 7712 20 *			
F 4035 04	32	16		1 7712 17		
F 4035 44			1 7712 17			
F 4035 05	40	25		1 7712 17		
F 4035 45			1 7712 17			
F 4035 16	50	40		1 7712 17		
F 4035 56			1 7712 17			
F 4035 07	65	63		1 7712 17		
F 4035 47			1 7712 17			
F 4035 08	80	100		1 7712 17		
F 4035 48			1 7712 17			
F 4035 09	100	160				direkte Montage
F 4035 49						direkte Montage
F 4035 10	125	250				direkte Montage
F 4035 50						direkte Montage
F 4035 41	150	330				direkte Montage
F 4035 52						direkte Montage
3-Wege Ventile						
F 4037 01	15	1	1 7712 20			
F 4037 11	15	1,6	1 7712 20			
F 4037 21	15	2,5	1 7712 20			
F 4037 31	15	4	1 7712 20			
F 4037 03	25	6,3	1 7712 20			
F 4037 13	25	10	1 7712 20			
F 4037 04	32	16		1 7712 17		
F 4037 05	40	25		1 7712 17		
F 4037 16	50	40		1 7712 17		
F 4037 07	65	63		1 7712 17		
F 4037 08	80	100		1 7712 17		
F 4037 09	100	160				direkte Montage
F 4037 10	125	250				direkte Montage
F 4037 41	150	330				direkte Montage
Mischer						
1 2137 11	15					
1 2137 12	20					
1 2137 13	25					
1 2137 14	32					
1 2137 15	40					
1 2137 16	50					
Kugelhähne						
1 2117 11	15					
1 2117 12	20					
1 2117 13	25					
1 2117 14	32					
1 2117 15	40					
1 2117 16	50					

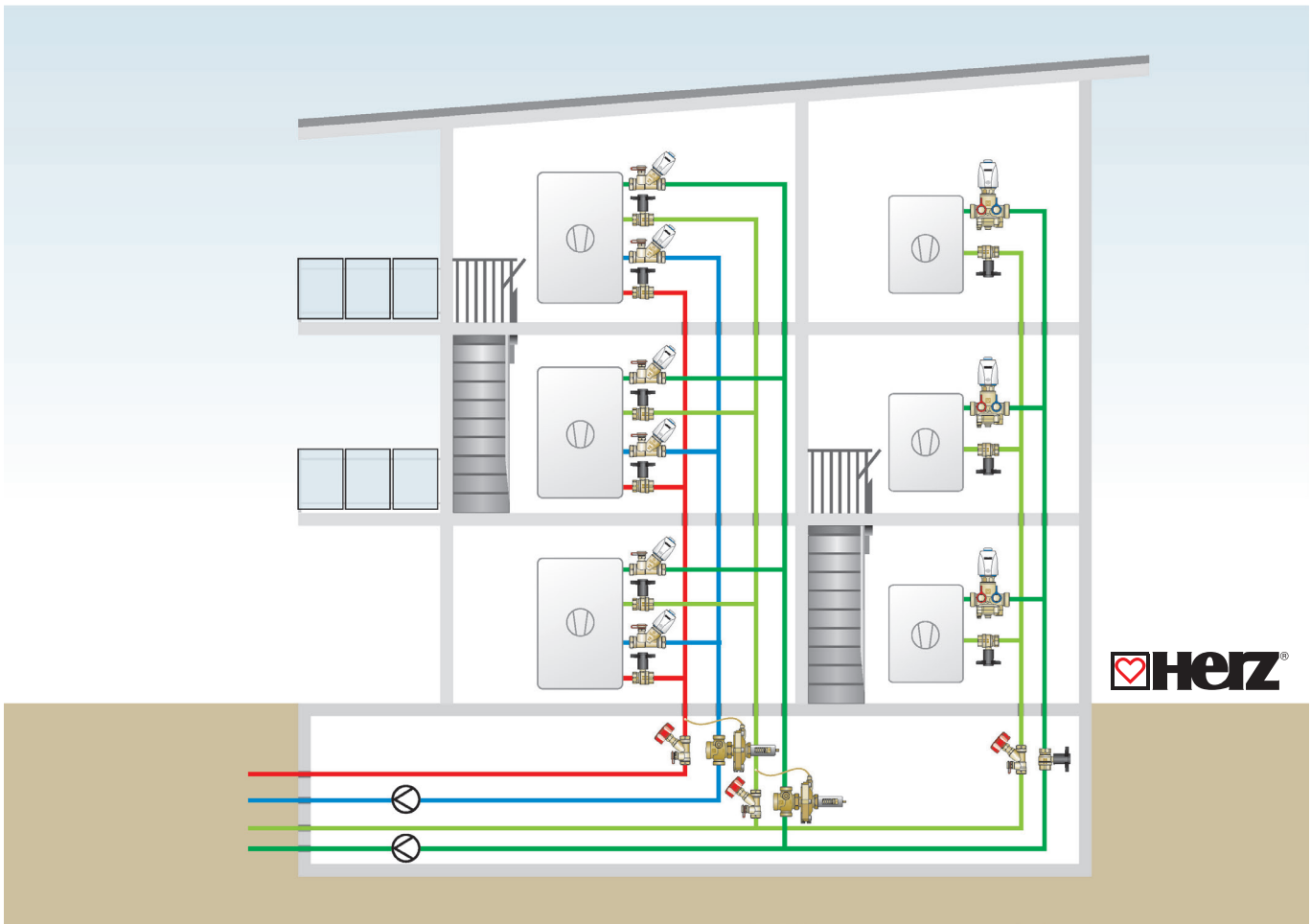
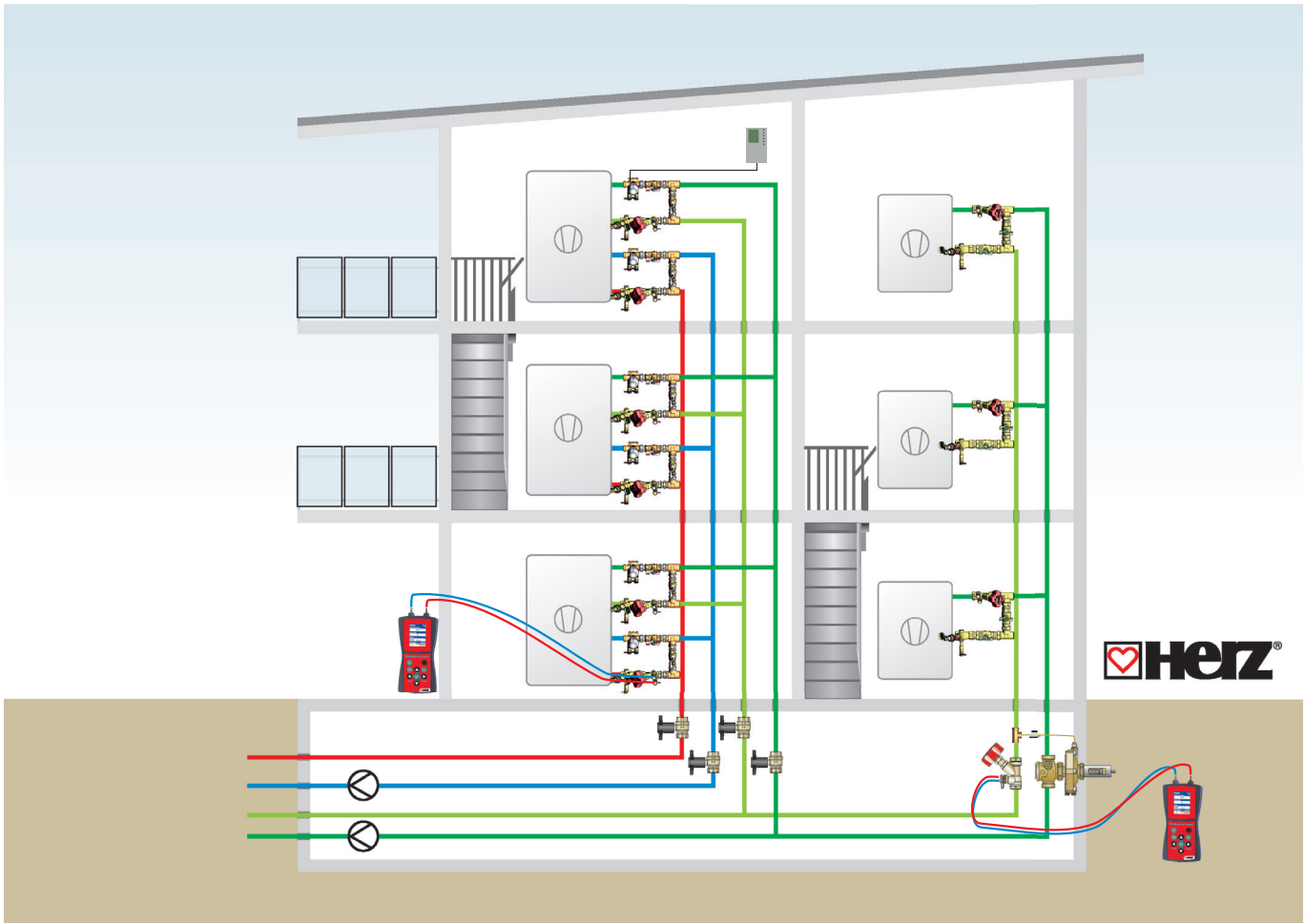

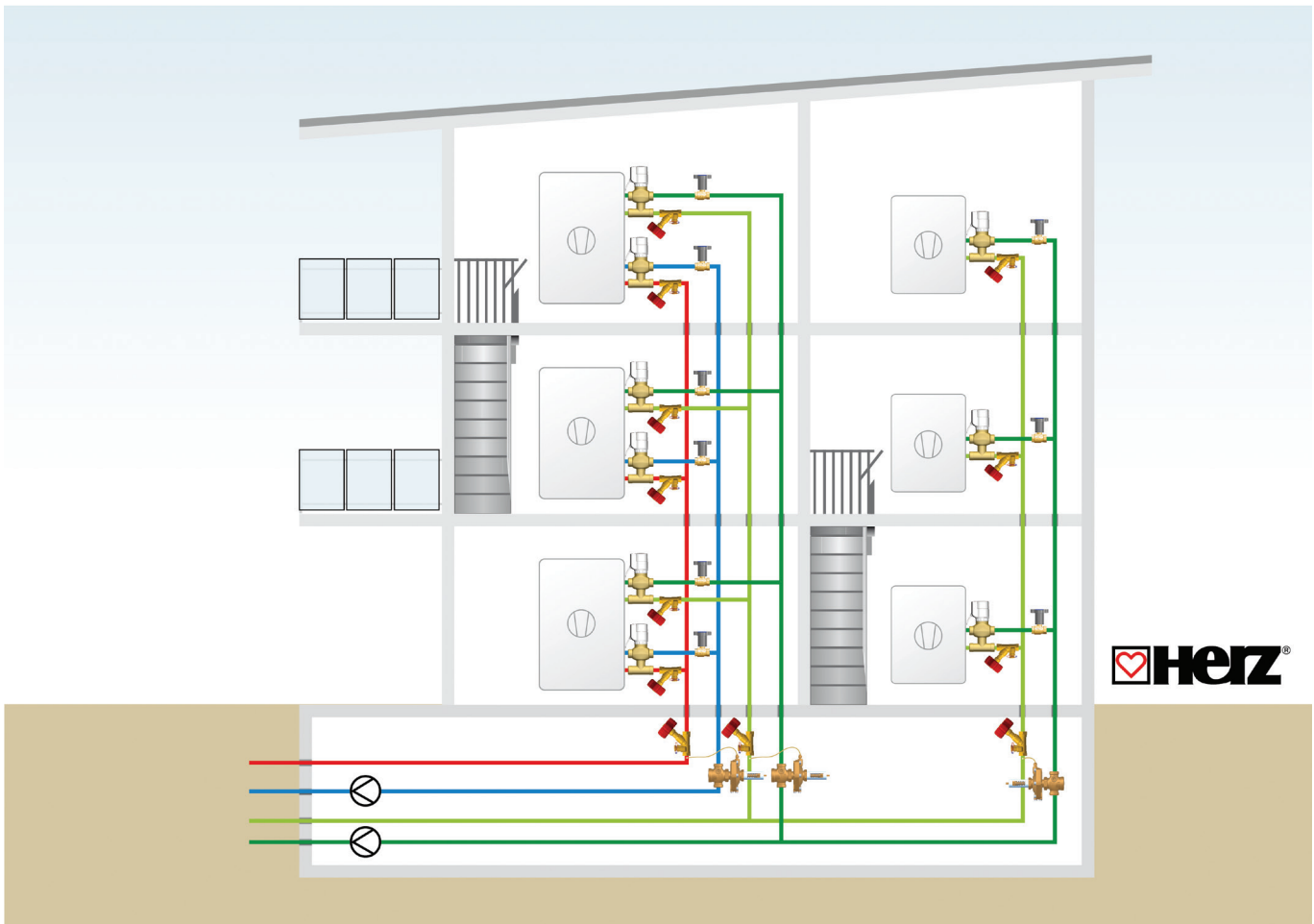
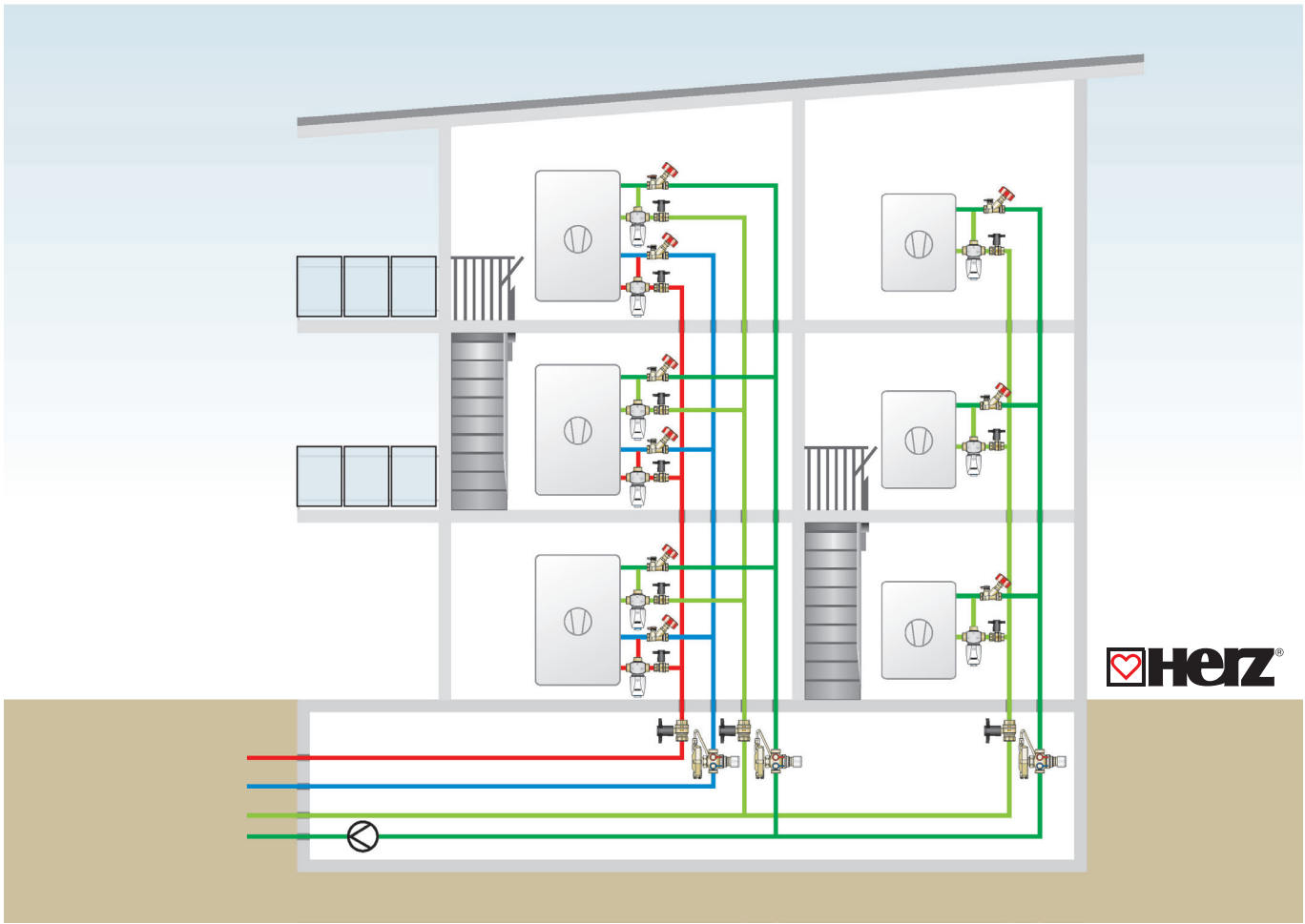

www.herz.eu
www.herz.ae



HERZ-Pressure Independent Control Valves



www.herz.eu
www.herz.ae



HERZ Integral Fixed Orifice Commissioning Valve



www.herz.eu



HERZ - Balancing Valves Cast Iron



www.herz.eu



Hydraulics in HVAC Applications



www.herz.eu



HERZ International



www.herz.eu
www.herz.ae

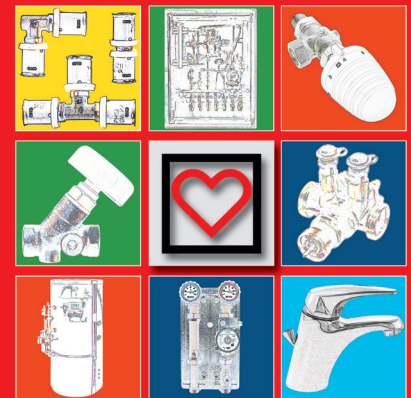

All specifications and statements within this brochure are according to information available at the time of printing and meant for informational purpose only. HERZ Armaturen reserves the right to modify and change products as well as its technical specifications and/or its functioning according to technological progress and requirements. It is understood that all images of HERZ products are symbolic representations and therefore may visually differ from the actual product. Colours may differ due to printing technology used. In case of any further questions don't hesitate to contact your closest HERZ Branch-office.

HERZ Middle East FZE
SAIF Zone, Sharjah, UAE
P.O.Box: 121310

Telephone: +971 (0)6 55 28 108
Fax: +971 (0)6 55 28 109

e-mail: office@herz.ae
web: www.herz.ae

INTERNATIONAL HEADQUARTERS

HERZ Armaturen Ges.m.b.H.
A-1230 Wien, Richard-Strauss-Strasse 22

Telephone: +43 (0)1 616 26 31-0
Fax: +43 (0)1 616 26 31-227

E-Mail: office@herz.eu
www.herz.eu



DVR 0092541
GLN 9004174000003
ARA 2102

Handelsgericht Wien
FN 101 622 w

